



# OneStream Hardware Installation

Version 5

## Document Control

Date	Document Version	Change
Oct 2006	1	First Draft Release of Document
June 2007	2	Antenna requirements
Jan 2008	3	Added OneStream Versions
Feb 2008	4	Added OneStream G
Nov 2008	5	Added OneStream BRI /GBRI

## Notices

### Guarantee

The OneStream is supplied with a 1-year return to base warranty which covers any defect in design or manufacture. No other warranties whatsoever are given.

If a faulty unit is required to be returned within the terms of the warranty a completed Returns Form (p.12) must be returned with the faulty unit.

TelecomFM shall accept no liability for any error or damages of any kind resulting from the use of this document or the equipment it relates to.

No responsibility is assumed by TelecomFM for the use or reliability of the OneStream when used in a situation or with other equipment not supplied or specified by TelecomFM.

The wording in this document may change from time to time. Please refer to the TelecomFM web site [www.telecomfm.co.uk](http://www.telecomfm.co.uk) for the latest release.

### **EC Declaration Of Conformity to R &TTE Directive 1999/5/EC**

Manufacturer: TelecomFM Development Ltd  
895 Plymouth Road  
Slough  
Berks  
SL1 4LP  
UK

Product/Apparatus: Onestream

Type Number: FX

#### Declaration:

I declare that above product conforms to all the applicable requirements of EU Directive 1999/5/EC and is CE-marked accordingly:

Article 3.1a: EN 60950-1:2001 LVD Directive  
EN 50392:2002 RF Exposure Evaluation

Article 3.1b: EN 301 489-7 V1.2.1 & EN 301 489-1 V1.6.1

Article 3.2: EN 301 511 V9.0.2

## CONTENTS

<b>1</b>	<b>SAFETY INSTRUCTIONS</b> .....	<b>3</b>
<b>2</b>	<b>PACKAGE CONTENTS</b> .....	<b>4</b>
<b>3</b>	<b>PRE-INSTALLATION</b> .....	<b>4</b>
3.1	PRE-INSTALLATION CHECKS .....	4
3.2	TOOLS REQUIRED .....	4
<b>4</b>	<b>INSTALLATION</b> .....	<b>5</b>
<b>5</b>	<b>UNDERSTANDING THE LEDS</b> .....	<b>9</b>
<b>6</b>	<b>BEFORE LEAVING SITE</b> .....	<b>9</b>
<b>7</b>	<b>TROUBLESHOOTING</b> .....	<b>10</b>

## 1 Safety Instructions

Failure to follow all instructions may result in improper operation of the TelecomFM OneStream and/or the risk of electrical shock.

All installation personnel should consult the information contained in this manual before attempting to install this product.

All installation engineers should adhere to the following instructions:

1. The OneStream should only be installed or maintained by qualified personnel who have been trained by TelecomFM or one of their certified representatives.
2. The OneStream should only be installed according to the instructions in this manual.
3. Do not attempt to connect the OneStream whilst the associated PABX is in use unless given prior permission to do so.
4. Do not attempt to install the OneStream during an electrical storm.

## 2 Package Contents

The unit will be supplied with:

1. OneStream Unit
2. Power Supply Unit
3. 2 x GSM Antennae with flexible coax (*G / GFX / GBRI units only*)
4. Unit Fixings
5. RJ45 cable(s)
6. Fixing Template
7. Hardware Installation Guide
8. Programming Guide
9. Safety Earth cable (SEG Safety Earth Ground)
10. Cable Tie

## 3 Pre-Installation

### 3.1 Pre-Installation Checks

Prior to the commencement of installation work, check with the customer that the interfaces (ISDN/FXS/FXO/GSM, etc.) on the paperwork are correct

Select a suitable location to install the OneStream unit.

- Close to a mains power supply (100-240V RMS AC 50-60Hz)
- Near an Ethernet socket

Poor locations would include:

- On walls that contain a large amount of wiring, steel, or metal construction material.
- On walls with unusually thick masonry.
- In metal buildings or in rooms with large areas of metal.
- Outside
- In locations which would expose OneStream to water, moisture or extreme temperatures (e.g. above radiators or in direct sunlight)

*(G / GFX / GBRI units only)* In order to optimise the signal strength the best locations are:

- On, or near an exterior wall
- Close to a window
- On the top floor of the building
- At least 1 metre away from any other sensitive electronic equipment

### 3.2 Tools Required

The minimum tools required to carry out an installation of a single OneStream unit are as follows:

- Screwdriver
- Power Drill

The following tools are recommended for installing OneStream GFX / FX:

- Multi-meter
- Digit Analyser
- Test Telephone handset
- Krone Tool

The following tools are recommended for installing OneStream GBRI / BRI:

- ISDN Test Phone

## 4 Installation

1. Using the fixing template, neatly locate and mount the OneStream in the optimum position ensuring that you install the OneStream and its antennae at least 1 metre away from any other sensitive electronic equipment.
2. *(FX / GFX Models Only)* Take the bottom cover off by removing the small countersink screw at the bottom of the OneStream and sliding downwards. This will give you access to the Krone connections if required.
3. *(FX / GFX Models Only)* Make all the physical connections from the Network Termination point to the OneStream FXO positions (Top) on the Krone board. Now make the wiring connections from the OneStream FXS positions (Bottom) to the PBX Equipment. Check line polarity before connection if lines used require this connectivity. When all physical wiring is complete secure the cables with the cable tie and slide the bottom cover back in place and fasten with countersink screw.

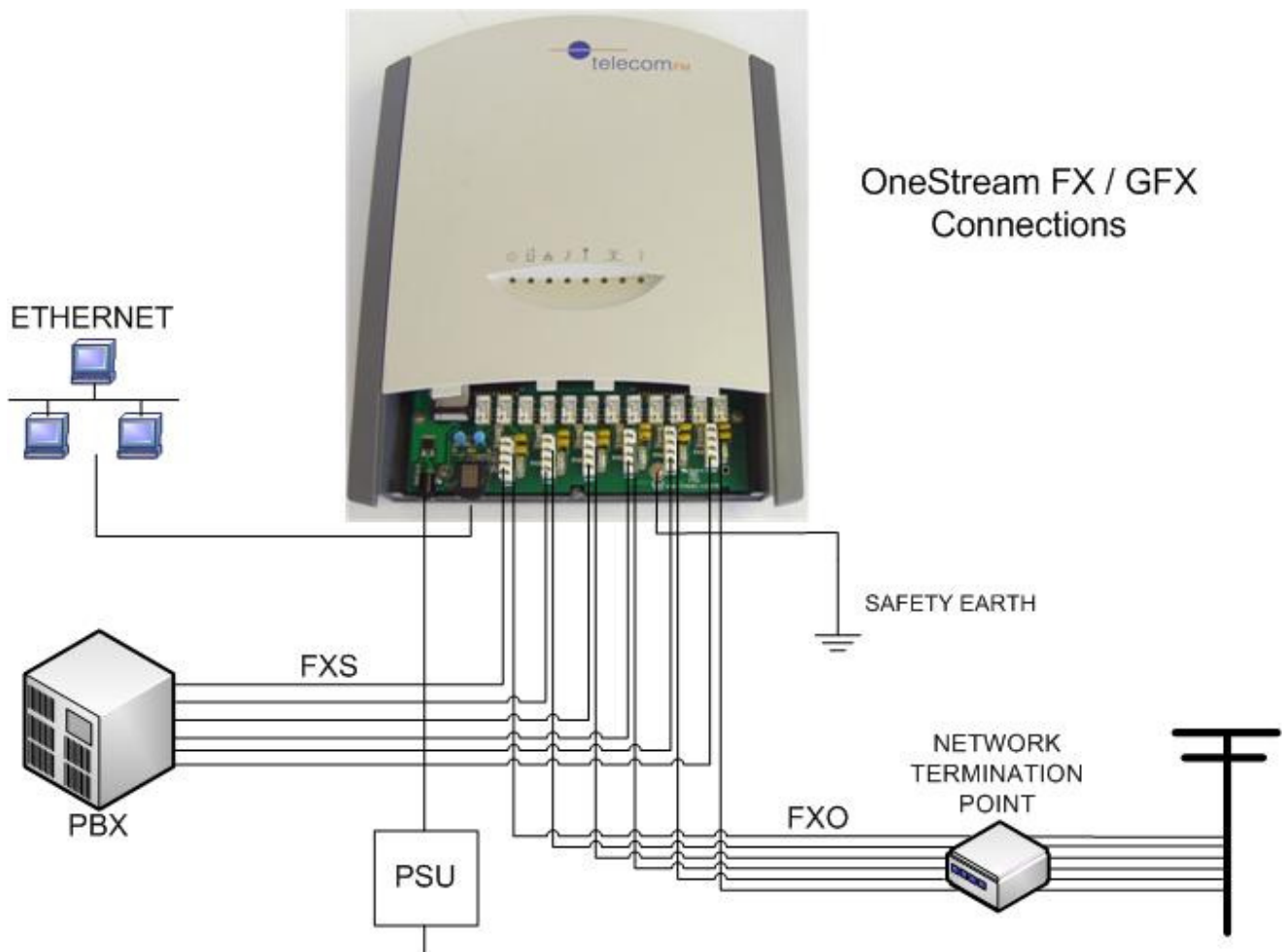

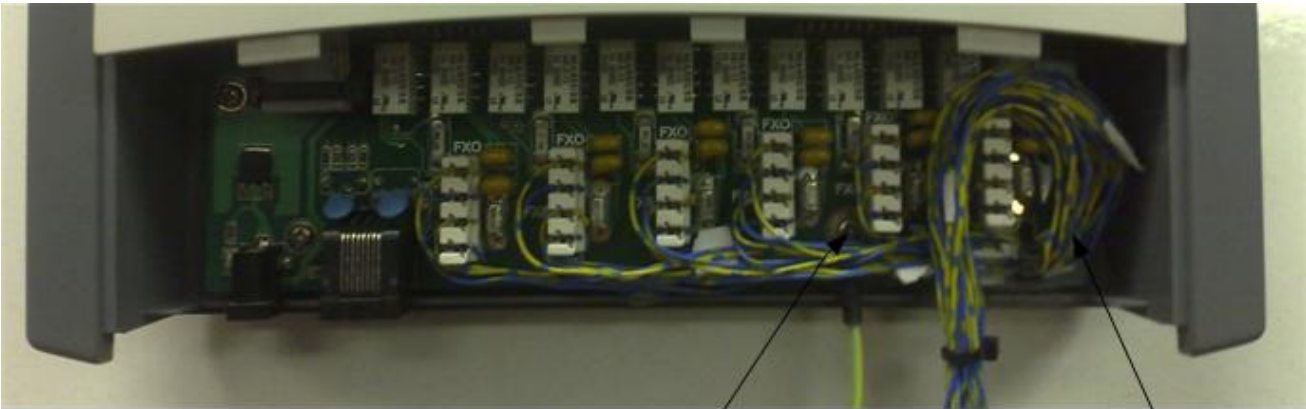

Safety Earth Ground

Cable Tie

# OneStream Hardware Installation Guide

- 4. (BRI / GBRI Models only) Remove the RJ45 cables, which are connected to the PBX, and connect them to OneStream's NT points. Use the RJ45 cables provided to connect OneStream's TE ports to the PBX.

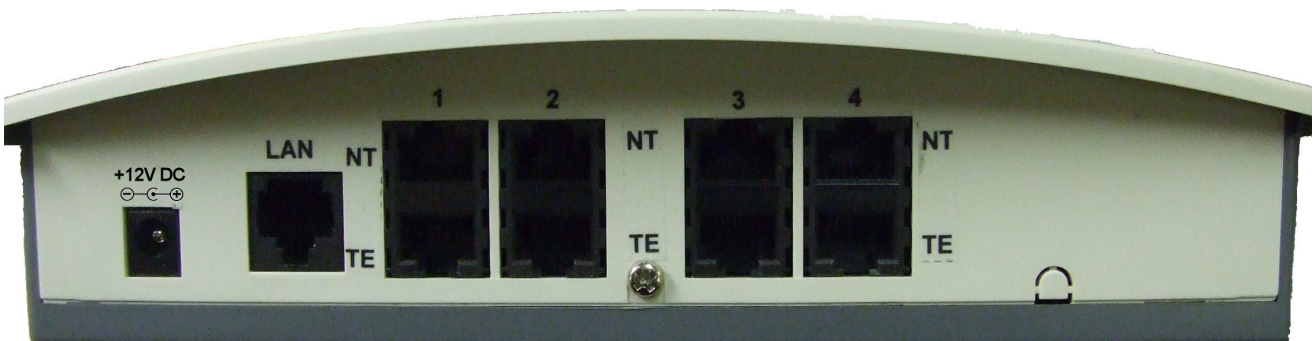
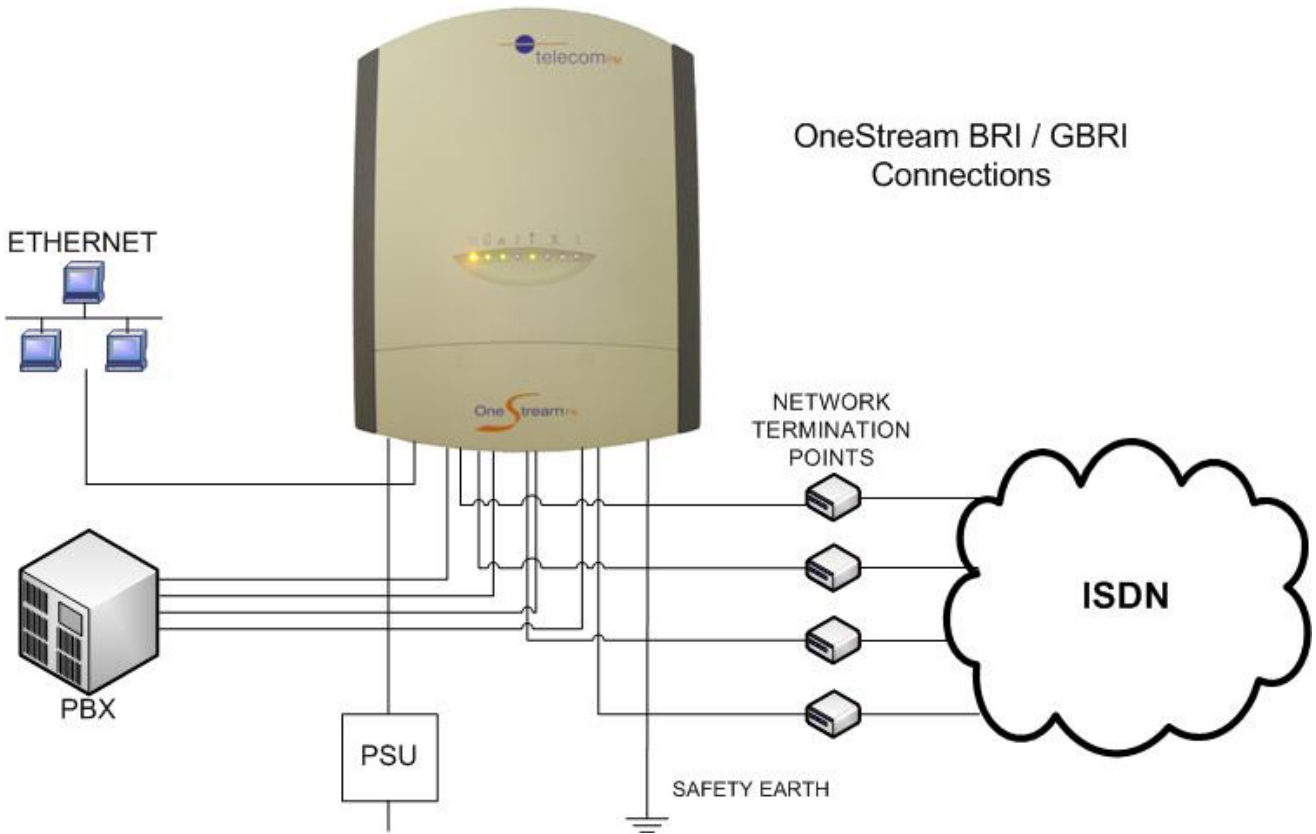

## OneStream Hardware Installation Guide

5. (*G / GFX / GBRI Models only*) Connect the Antennae - it is recommended that the antennae are fixed a Minimum of 300mm apart horizontally. Antennae with a flexible coax cable should always be used with the Onestream product. Connect the SIM(s) into the side slots making sure the PIN contacts are facing the back of the unit.

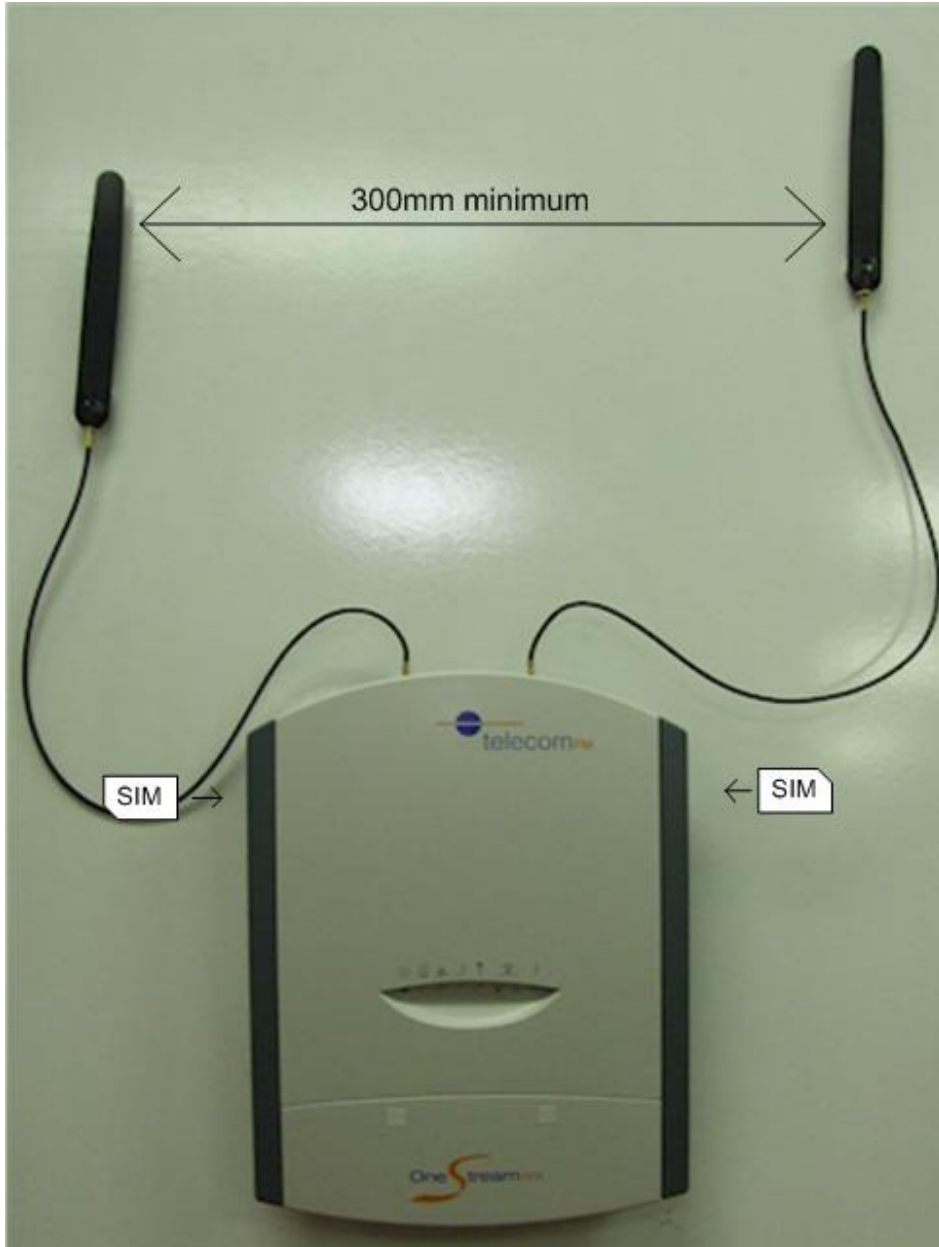

6. Connect the Safety Earth Ground to a suitable ground point with the wire supplied.
7. Plug the RJ45 cable, which is provided, into the Ethernet port at the bottom of the OneStream and the other end into your chosen Ethernet socket.
8. Connect the power to the unit.
9. Refer to the OneStream Programming Guide to configure the unit.

### Note on power failure:

In the event of loss of power to the unit, the FXS / TE lines connected through the OneStream will be connected to the corresponding FXO / NT lines by means of a "Metallic" by-pass mechanism.

**5 Understanding the LEDs**

When power is connected to the OneStream, initialisation will begin. The Power and Warning LEDs will be ON. When the unit has initialized the Warning LED goes OFF.



Power LED - Indicates that the Unit is powered On



GSM LED - ON indicates that a GSM Call is Active  
Flashing indicates a GSM Fault or configuration error



IP LED - ON indicates that a VoIP Call is Active  
Flashing indicates an IP Fault or configuration error



FXS / TE LED ON indicates that an FXS / TE Call is Active  
Flashing indicates an FXS / TE Fault or configuration error



FXO / NT LED ON indicates that an FXO / NT Call is Active  
Flashing indicates an FXO / NT Fault or configuration error



SIGNAL STRENGTH LED's Between 1 and 5 flashes to indicate the GSM Signal Strength.



WARNING LED ON indicates the unit is not ready for calls (during initialization or because a fault has occurred)

**6 Before Leaving Site**

- Test each active interface for a 2 way conversation.
- Advise the Customer of their new GSM numbers (where applicable).
- Fill in all site documentation
- Obtain an acceptance signature from the customer
- Leave a copy of the documentation with the customer, this will be the site record.

## 7 Troubleshooting

<b>Problem</b>	<b>Recommendations</b>
The Power LED does not light	Check the mains power.
The GSM LED is flashing	Check the SIMs are correctly inserted. Check the SIMs do not require a PIN Check the Antennae connections are secure. Check the Signal Strength Check any unused GSM ports are not selected in the Group configuration
The IP LED is flashing	Check the Ethernet port is connected Check the webpage for Registration errors
The FXO / NT LED is flashing	Check any unused FXO / NT ports are not selected in the Group configuration
The Warning LED remains ON	The unit has experienced a fault. Contact Technical Support
Signal Strength LED does not flash	Check the Antennae connections are secure Check the OneStream is positioned correctly