INDEX

I. Application..... 4

II. Preparation 5

2. Connectors and wiring 5

2.1 RS-232C Remote control..... 5

2.2 LAN control 5

III. Communication specification 7

3. Communication Parameter 7

3.1 RS-232C Remote control..... 7

3.2 LAN control 7

3.3 Communication timing 7

4. Communication Format 8

4.1 Header block format (fixed length) 9

4.2 Message block format 11

4.3 Check code 13

4.4 Delimiter 14

5. Message type..... 15

5.1 Get current Parameter from a monitor. 15

5.2 "Get parameter" reply 16

5.3 Set parameter 18

5.4 "Set parameter" reply 19

5.5 Commands 20

5.5.1 Save Current Settings..... 20

5.5.2 Get Timing Report and Timing reply. 21

5.5.3 NULL Message 22

IV. Control Commands 23

6. Typical procedure example 23

6.1. How to change the "Backlight" setting. 23

6.2. How to read the measurement value of the built-in temperature sensors..... 26

6.3. Operation Code (OP code) Table 29

7. Power control procedure 45

7.1 Power status read 45

7.2 Power control 47

8. Asset Data read and write 49

8.1 Asset Data Read Request and reply..... 49

8.2 Asset Data write.....	50
9. Date & Time read and write.....	51
9.1 Date & Time Read	51
9.2 Date & Time Write	53
10. Self diagnosis	56
10.1 Self-diagnosis status read	56
11. Serial No. & Model Name Read	58
11.1 Serial No. Read.....	58
11.2 Model Name Read	60
12. Security Lock.....	62
12.1 Security Lock Control	62
13. Direct TV Chanel Read & Write	64
13.1 Direct TV Chanel Read & Reply.....	64
13.2 Direct TV Chanel Write & Reply	65
14. Daylight Saving read & write.....	66
14.1 Daylight Saving Read	66
14.2 Daylight Saving Write.....	68
15. Firmware Version	70
15.1 Firmware Version Read.....	70
16. Auto ID	72
16.1 Auto ID Execute.....	72
16.2 Auto ID Complete	73
16.3 Auto ID Reset.....	74
17. Input Name	75
17.1 Input Name Read.....	75
17.2 Input Name Write	77
17.3 Input Name Reset.....	79
18. Auto Tile Matrix	80
18.1 Auto Tile Matrix Execute	80
18.2 Auto Tile Matrix Complete.....	82
18.3 Auto Tile Matrix Monitors Read.....	83
18.4 Auto Tile Matrix Monitors Write	84
18.5 Auto Tile Matrix Reset	85
19. Power Save Mode	86
19.1 Auto Power Save Time Read	86
19.2 Auto Power Save Time Write.....	87
19.3 Auto Standby Time Read	88
19.4 Auto Standby Time Write.....	89

20. Setting Copy	90
20.1 Setting Copy Read.....	90
20.2 Setting Copy Write	92
20.3 Setting Copy Start.....	94
21. Security Enable	95
21.1 Security Enable Read.....	95
21.2 Security Enable Write	96
22. LAN MAC Address	98
22.1 LAN MAC Address Read.....	98
23. Proof of Play.....	100
23.1 Set Proof of Play Operation Mode	100
23.2 Get Proof of Play Current.....	102
23.3 Get Proof of Play Status.....	105
23.4 Get Proof of Play Number to Number	107
24. Setting Lock of COMPUTE MODULE.....	109
24.1 Setting Lock Control	109
25. Emergency Contents.....	111
25.1 Emergency Contents Display.....	111
26.2 Emergency Contents Delete	113

I. Application

This document defines the communications method for control of the NEC LCD monitor, MultiSync P404 /P484 /P554 /V404 /V484 /V554 when using an external controller.

II. Preparation

2. Connectors and wiring

2.1 RS-232C Remote control

Connector: 9-pin D-Sub

Cable: Cross (reversed) cable or null modem cable

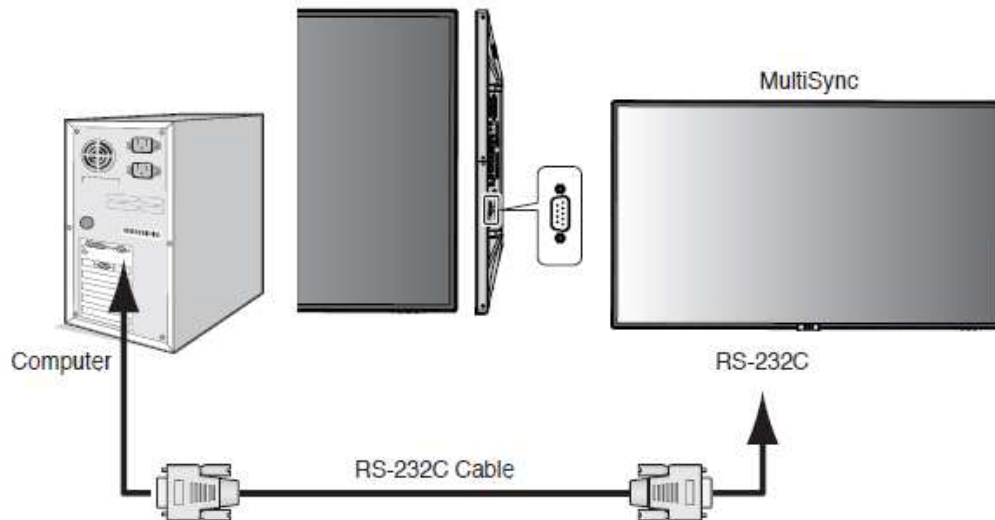

(Please refer "Controlling the LCD monitor via RS-232C Remote control" on User's manual.)

2.2 LAN control

Connector: RJ-45 10/100 BASE-T

Cable: Category 5 or higher LAN cable

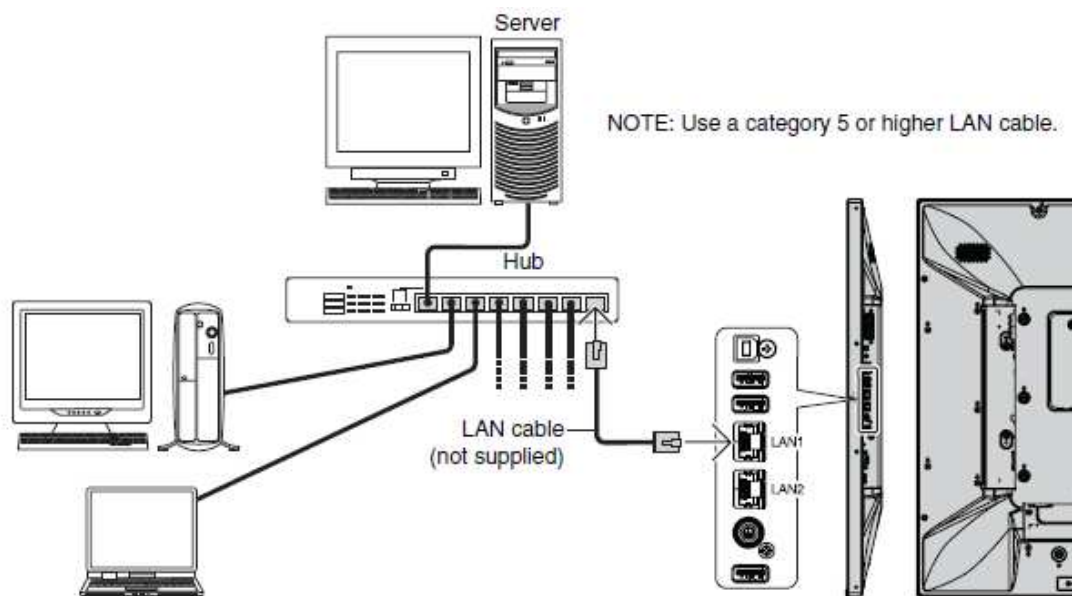

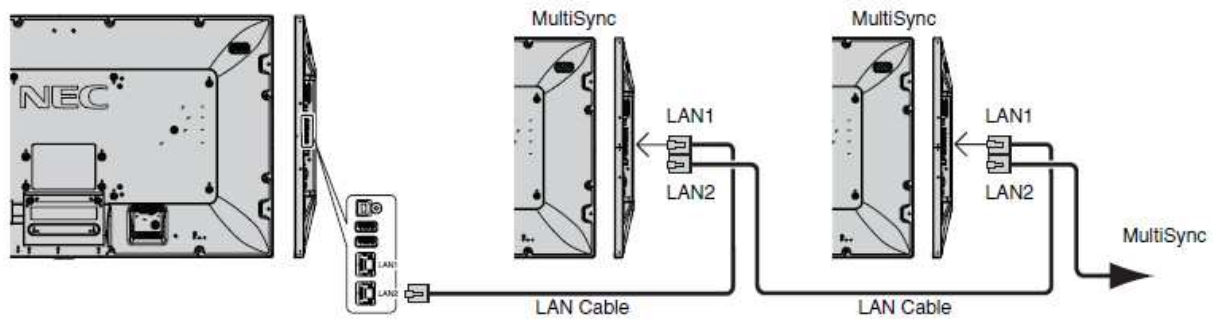

(Please refer "Controlling the LCD monitor via LAN control" on User's manual.)

III. Communication specification

3. Communication Parameter

3.1 RS-232C Remote control

(1) Communication system	Asynchronous
(2) Interface	RS-232C
(3) Baud rate	9600bps
(4) Data length	8bits
(5) Parity	None
(6) Stop bit	1 bit
(7) Communication code	ASCII

3.2 LAN control

(1) Communication system	TCP/IP (Internet protocol suite)
(2) Interface	Ethernet (CSMA/CD)
(3) Communication layer	Transport layer (TCP) * Using the payload of TCP segment.
(4) IP address	(Default) Automatic setup * If you need to change, Please refer "Network settings" on User's manual.
(5) Port No.	7142 (Fixed)

(Note)

The monitor will disconnect the connection if no packet data is received for 15 minutes.
And the controller (PC) has to re-connect to control the monitor again, after 15 minutes or more.

3.3 Communication timing

The controller should wait for a reply packet before the next command is sent.

(Note)

When the following commands are sent, a controller should wait for specified period after receiving the reply command before sending the next command.

- Power On, Power Off: 15 seconds
- Input, PIP Input, Auto Setup, Factory Reset: 10 seconds

4. Communication Format

Header	Message	Check Code	Delimiter
--------	---------	------------	-----------

The command packet consists of four parts, Header, Message, Check code and Delimiter.
 Note: Don't add extra data (Example: padding data) after Delimiter.

Recommended sequence of a typical procedure to control a monitor is as follows,
 [A controller and a monitor, two-way communication composition figure]

- For the general command (see the part "6.3. Operation Code (OP code) Table")

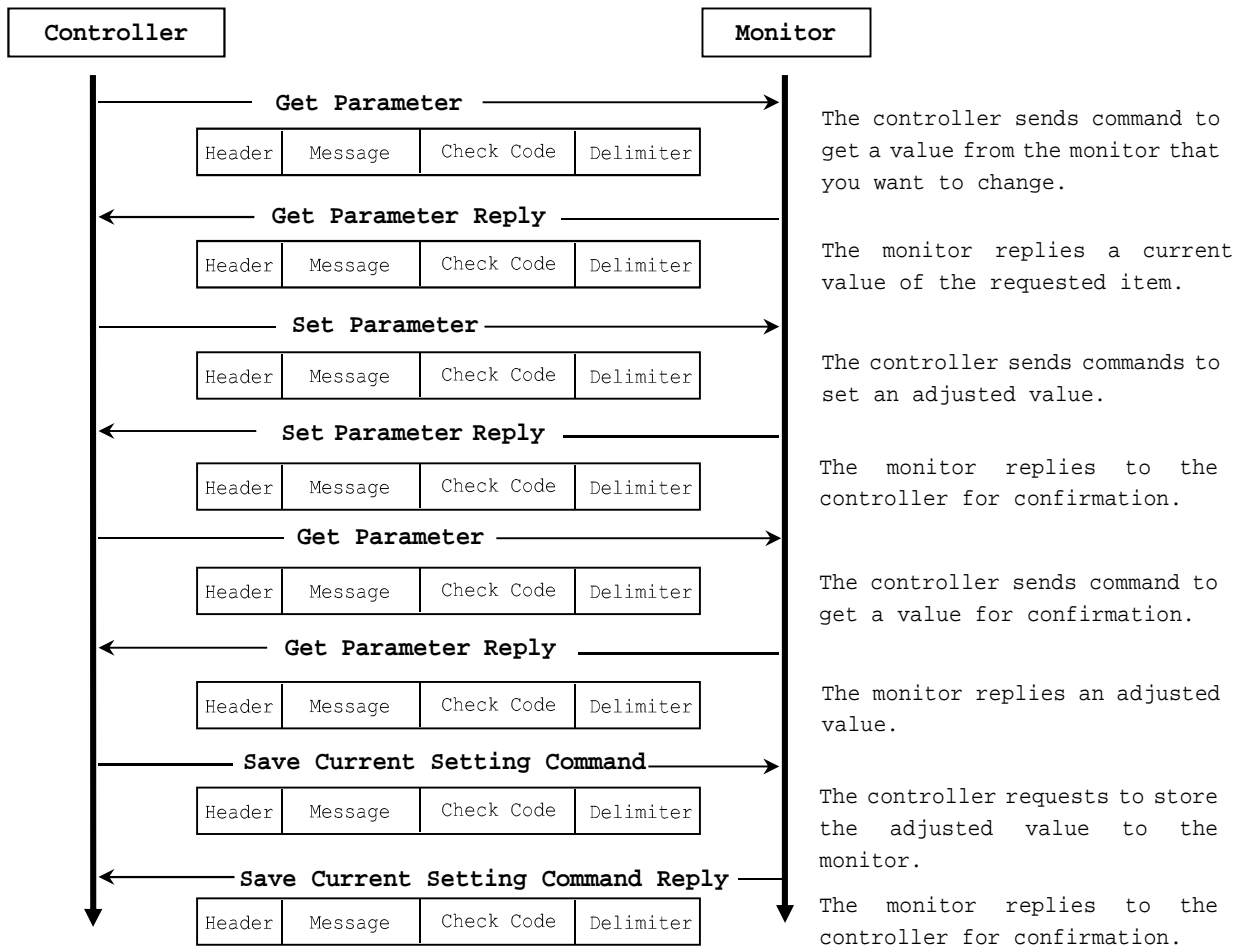

- For the special command (see the part 7 to 24. and 5.5.2)

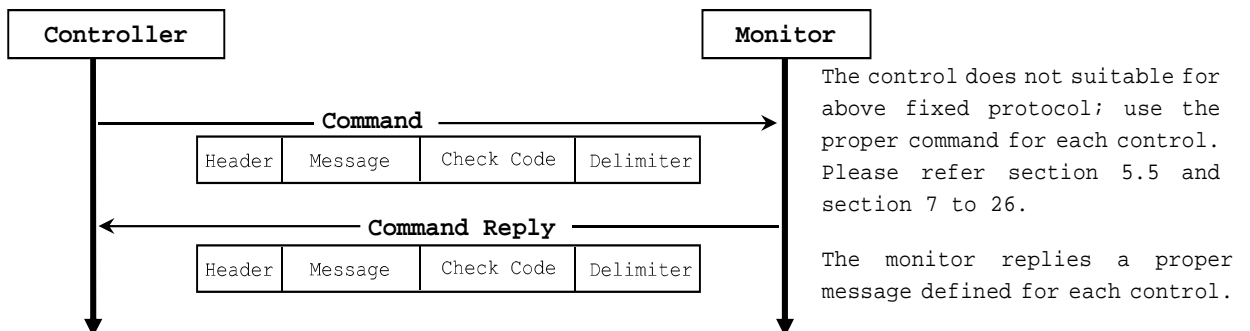

4.1 Header block format (fixed length)

Header	Message	Check code	Delimiter
--------	---------	------------	-----------

SOH	Reserved '0'	Destination	Source	Message Type	Message Length
1 st	2 nd	3 rd	4 th	5 th	6 th - 7 th

1stbyte) SOH: Start of Header

ASCII SOH (01h)

2ndbyte) Reserved: Reserved for future extensions.

On this monitor, it must be ASCII '0'(30h).

3rdbyte) Destination: Destination equipment ID. (Receiver)

Specify a commands receiver's address.

The controller sets the "MONITOR ID" or "GROUP ID" of the monitor controlled in here.

On the reply, the monitor sets '0' (30h), always.

"MONITOR ID", "GROUP ID" to "Destination Address" conversion table is as follows,

Monitor ID	Destination Address	Monitor ID	Destination Address	Monitor ID	Destination Address	Monitor ID	Destination Address
1	41h('A')	26	5Ah('Z')	51	73h	76	8Ch
2	42h('B')	27	5Bh	52	74h	77	8Dh
3	43h('C')	28	5Ch	53	75h	78	8Eh
4	44h('D')	29	5Dh	54	76h	79	8Fh
5	45h('E')	30	5Eh	55	77h	80	90h
6	46h('F')	31	5Fh	56	78h	81	91h
7	47h('G')	32	60h	57	79h	82	92h
8	48h('H')	33	61h	58	7Ah	83	93h
9	49h('I')	34	62h	59	7Bh	84	94h
10	4Ah('J')	35	63h	60	7Ch	85	95h
11	4Bh('K')	36	64h	61	7Dh	86	96h
12	4Ch('L')	37	65h	62	7Eh	87	97h
13	4Dh('M')	38	66h	63	7Fh	88	98h
14	4Eh('N')	39	67h	64	80h	89	99h
15	4Fh('O')	40	68h	65	81h	90	9Ah
16	50h('P')	41	69h	66	82h	91	9Bh
17	51h('Q')	42	6Ah	67	83h	92	9Ch
18	52h('R')	43	6Bh	68	84h	93	9Dh
19	53h('S')	44	6Ch	69	85h	94	9Eh
20	54h('T')	45	6Dh	70	86h	95	9Fh
21	55h('U')	46	6Eh	71	87h	96	A0h
22	56h('V')	47	6Fh	72	88h	97	A1h
23	57h('W')	48	70h	73	89h	98	A2h
24	58h('X')	49	71h	74	8Ah	99	A3h
25	59h('Y')	50	72h	75	8Bh	100	A4h
ALL	2Ah('*')						

Group ID	Destination Address	Group ID	Destination Address	Group ID	Destination Address	Group ID	Destination Address
A	31h('1')	D	34h('4')	G	37h('7')	J	3Ah(':')
B	32h('2')	E	35h('5')	H	38h('8')		
C	33h('3')	F	36h('6')	I	39h('9')		

Ex.) If you want to control a monitor that has the "ID No." as '1', specify a destination address 'A' (41h). If you want to control all of the monitors which are connected by a daisy chain, specify a destination address '*' (2Ah).

4th byte) Source: Source equipment ID. (Sender)

Specify a sender address.

The controller must be '0' (30h).

On the reply, the monitor sets the own MONITOR ID in here.

5th byte) Message Type: (Case sensitive.)

Refer to section 4.2 "Message block format" for more details.

ASCII 'A' (41h): Command.

ASCII 'B' (42h): Command reply.

ASCII 'C' (43h): Get current parameter from a monitor.

ASCII 'D' (44h): "Get parameter" reply.

ASCII 'E' (45h): Set parameter.

ASCII 'F' (46h): "Set parameter" reply.

6th -7th bytes) Message Length:

Specify the length of the message (that follows the header) from STX to ETX.

This length includes STX and ETX.

The byte data must be encoded to ASCII characters.

Ex.) The byte data 3Ah must be encoded to ASCII characters '3' and 'A' (33h and 41h).

The byte data 0Bh must be encoded to ASCII characters '0' and 'B' (30h and 42h).

4.2 Message block format

Header	Message	Check code	Delimiter
--------	----------------	------------	-----------

"Message block format" is allied to the "Message Type" in the "Header".

Refer to the section 4.1 "Header block format" for more detail.

1)Get current parameter

The controller sends this message when you want to get the status of the monitor.

For the status that you want to get, specify the "OP code page" and "OP code",

refer to "Appendix A. Operation code table".

"Message format" of the "Get current parameter" is as follows,

STX	OP code page		OP code		ETX
	Hi	Lo	Hi	Lo	

➤ Refer to section 5.1 "Get current parameter from a monitor." for more details.

2)Get Parameter reply

The monitor will reply with the status of the requested item specified by the controller in the "Get parameter message".

"Message format" of the "Get parameter reply" is as follows,

STX	Result		OP code page		OP code		Type		Max value			Current Value			ETX
	Hi	Lo	Hi	Lo	Hi	Lo	Hi	Lo	MSB		LSB	MSB		LSB	

➤ Refer to section 5.2 "Get parameter reply" for more details.

3)Set parameter

The controller sends this message to change a setting of the monitor.

Message format of the "Set parameter" is as follows,

STX	OP code page		OP code		Set Value			ETX
	Hi	Lo	Hi	Lo	MSB		LSB	

➤ Refer to section 5.3 "Set parameter" for more details.

4)Set Parameter reply

The monitor replies with this message for a confirmation of the "Set parameter message".

Message format of the "Set parameter reply" is as follows,

STX	Result		OP code page		OP code		Type		Max value			Requested setting Value			ETX
	Hi	Lo	Hi	Lo	Hi	Lo	Hi	Lo	MSB		LSB	MSB		LSB	

➤ Refer to section 5.4 "Set parameter reply" for more details.

5)Command

"Command message" format depends on each command.

Usually, this "command message" is used for some non-slider controls and some special operations, such as "Save current settings", "Get timing report", "power control", "Schedule", etc. Refer to

section 5.5 "Commands message" for more details.

6) Command reply

The monitor replies to a query from the controller.

"Command reply message" format depends on each command.

Refer to section 5.5 "Commands message" for more details.

4.3 Check code

Header	Message	Check code	Delimiter
--------	---------	------------	-----------

Check code is the Block Check Code (BCC) between the Header and the End of Message except SOH.

		2^7	2^6	2^5	2^4	2^3	2^2	2^1	2^0
SOH	D_0								
Reserved	D_1								
Destination	D_2								
Source	D_3								
Type	D_4								
Length(H)	D_5								
Length(L)	D_6								
STX	D_7								
Data	D_8								
ETX	D_n								
Check code	D_{n+1}	P	P	P	P	P	P	P	P

$$D_{n+1} = D_1 \text{ XOR } D_2 \text{ XOR } D_3 \text{ XOR } \dots \text{ XOR } D_n$$

XOR: Exclusive OR

Following is an example of a Check code (BCC) calculation.

Header						Message										Check code (BCC)	Delimiter	
SOH	Reserved	Destination Address	Source Address	Message type	Message length	STX	OP code page		Set Value				ETX					
01	30	41	30	45	30	41	02	30	30	31	30	30	30	36	34	03	77	0D
D_0	D_1	D_2	D_3	D_4	D_5	D_6	D_7	D_8	D_9	D_{10}	D_{11}	D_{12}	D_{13}	D_{14}	D_{15}	D_{16}	D_{17}	D_{18}

$$\begin{aligned}
 \text{Check code (BCC) } D_{17} &= D_1 \text{ xor } D_2 \text{ xor } D_3 \text{ xor } \dots \text{ xor } D_{14} \text{ xor } D_{15} \text{ xor } D_{16} \\
 &= 30\text{h xor } 41\text{h xor } 30\text{h xor } 45\text{h xor } 30\text{h xor } 41\text{h} \\
 &\quad \text{xor } 02\text{h xor } 30\text{h xor } 30\text{h xor } 31\text{h xor } 30\text{h xor } 30\text{h} \\
 &\quad \text{xor } 30\text{h xor } 36\text{h xor } 34\text{h xor } 03\text{h} \\
 &= 77\text{h}
 \end{aligned}$$

4.4 Delimiter

Header	Message	Check code	Delimiter
--------	---------	------------	------------------

Packet delimiter code; ASCII CR(0Dh).

5. Message type

5.1 Get current Parameter from a monitor.

STX	OP code page		OP code		ETX
	Hi	Lo	Hi	Lo	
1 st	2 nd -3 rd		4 th -5 th		6 th

Send this message when you want to get the status of a monitor.

For the status that you want to get, specify the "OP code page" the "OP code", refer to "Appendix A. Operation code table".

1stbyte) STX: Start of Message

ASCII STX (02h)

2nd-3rdbytes) OP code page: Operation code page.

Specify the "OP code page" for the control which you want to get the status.

Refer to "Appendix A Operation code table" for each item.

OP code page data must be encoded to ASCII characters.

Ex.) The byte data 02h must be encoded to ASCII characters '0' and '2' (30h and 32h).

OP code page 02h -> OP code page (Hi) = ASCII '0' (30h)

OP code page (Lo) = ASCII '2' (32h)

Refer to Operation code table. (Appendix A)

4th-5thbytes) OP code: Operation code

Refer to "Appendix A Operation code table" for each item.

OP code data must be encoded to ASCII characters.

Ex.) The byte data 3Ah must be encoded to ASCII characters '3' and 'A' (33h and 41h).

OP code 3Ah -> OP code (Hi) = ASCII '3' (33h)

OP code (Lo) = ASCII 'A' (41h)

Refer to Operation code table.

6thbyte) ETX: End of Message

ASCII ETX (03h)

5.2 "Get parameter" reply

STX	Result		OP code page		OP code		Type		Max value			Current Value			ETX
	Hi	Lo	Hi	Lo	Hi	Lo	Hi	Lo	MSB		LSB	MSB		LSB	
1 st	2 nd -3 rd		4 th -5 th		6 th -7 th		8 th -9 th		10 th -13 th			14 th -17 th			18 th

The monitor replies with a current value and the status of the requested item (operation code).

1stbyte) STX: Start of Message

ASCII STX (02h)

2nd-3rdbytes) Result code.

These bytes indicate a result of the requested commands as follows,

00h: No Error.

01h: Unsupported operation with this monitor or unsupported operation under current condition.

This result code from the monitor is encoded to ASCII characters.

Ex.) The byte data 01h is encoded to ASCII character '0' and '1' (30h and 31h).

4th-5thbytes) OP code page: Operation code page.

These bytes indicate a replying item's OP code page.

This returned value from the monitor is encoded to ASCII characters.

Ex.) The byte data 02h is encoded to ASCII character '0' and '2' (30h and 32h).

Refer to the operation code table.

6th-7thbytes) OP code: Operation code

These bytes indicate a replying item's OP code.

This returned value from the monitor is encoded to ASCII characters.

Refer to the operation code table.

Ex.) The byte data 1Ah is encoded to ASCII character '1' and 'A' (31h and 41h).

8th-9thbytes) Type: Operation type code

00h: Set parameter

01h: Momentary

Like the Auto Setup function which automatically changes the parameter.

This returned value from the monitor is encoded to ASCII characters.

Ex.) The byte data 01h is encoded to ASCII character '0' and '1' (30h and 31h).

10th-13thbytes) Max. value: Maximum value which monitor can accept. (16bits)

This returned value from the monitor is encoded to ASCII characters.

Ex.) '0','1','2' and '3' means 0123h (291)

14th-17thbytes) Current Value: (16bits)

This returned value from the monitor is encoded to ASCII characters.

Ex.) '0','1','2' and '3' means 0123h (291)

18th byte) ETX: End of Message

ASCII ETX (03h)

5.3 Set parameter

STX	OP code page		OP code		Set Value				ETX
	Hi	Lo	Hi	Lo	MSB			LSB	
1 st	2 nd -3 rd		4 th -5 th		6 th -9 th				10 th

Send this message to change monitor's adjustment and so on.

The controller requests a monitor to change value.

1stbyte) STX: Start of Message

ASCII STX (02h)

2nd-3rdbytes) OP code page: Operation code page

This OP code page data must be encoded to ASCII characters.

Ex.) The byte data 02h must be encoded to ASCII '0' and '2' (30h and 32h).

Refer to the Operation code table.

4th-5thbytes) OP code: Operation code

This OP code data must be encoded to ASCII characters.

Ex.) OP code 1Ah -> OP code (Hi) = ASCII '1' (31h)

OP code (Lo) = ASCII 'A' (41h)

Refer to the Operation code table.

6th-9thbytes) Set value: (16bit)

This data must be encoded to ASCII characters.

Ex.) 0123h -> 1st(MSB) = ASCII '0' (30h)

2nd = ASCII '1' (31h)

3rd = ASCII '2' (32h)

4th(LSB) = ASCII '3' (33h)

10thbyte) ETX: End of Message

ASCII ETX (03h)

5.4 "Set parameter" reply

STX	Result		OP code page		OP code		Type		Max value				Requested setting Value				ETX
	Hi	Lo	Hi	Lo	Hi	Lo	Hi	Lo	MSB			LSB	MSB			LSB	
1 st	2 nd -3 rd		4 th -5 th		6 th -7 th		8 th -9 th		10 th -13 th				14 th -17 th				18 th

The Monitor echoes back the parameter and status of the requested operation code.

1stbyte) STX: Start of Message

ASCII STX (02h)

2nd-3rdbytes) Result code

ASCII '0' '0' (30h, 30h): No Error.

ASCII '0' '1' (30h, 31h): Unsupported operation with this monitor or unsupported operation under current condition.

4th-5thbytes) OP code page: Echoes back the Operation code page for confirmation.

Reply data from the monitor is encoded to ASCII characters.

Ex.) OP code page 02h -> OP code page = ASCII '0' and '2' (30h and 32h)

Refer to Operation code table.

6th-7thbytes) OP code: Echoes back the Operation code for confirmation.

Reply data from the monitor is encoded to ASCII characters.

Ex.) OP code 1Ah -> OP code (Hi) = ASCII '1' (31h)

OP code (Lo) = ASCII 'A' (41h)

Refer to Operation code table

8th-9thbytes) Type: Operation type code

ASCII '0' '0' (30h, 30h): Set parameter

ASCII '0' '1' (30h, 31h): Momentary

Like Auto Setup function, that automatically changes the parameter.

10th-13thbytes) Max. value: Maximum value that monitor can accept. (16bits)

Reply data from the monitor is encoded to ASCII characters.

Ex.) '0' '1' '2' '3' means 0123h (291)

14th-17thbytes) Requested setting Value: Echoes back the parameter for confirmation. (16bits)

Reply data from the monitor is encoded to ASCII characters.

Ex.) '0' '1' '2' '3' means 0123h (291)

18thbyte) ETX: End of Message

ASCII ETX (03h)

5.5 Commands

"Command message format" depends on each command. Some commands are shown with usage. Refer to section 7 to 25.

5.5.1 Save Current Settings.

The controller requests for the monitor to store the adjusted value.

STX	Command code		ETX
	'0'	'C'	

- Send "OC"(30h, 43h) as Save current settings command.
- Complete "Save Current setting" command packet as follows;

ASCII: 01h-30h-41h-30h-41h-30h-34h-02h-30h-43h-03h-CHK-0Dh

SOH-'0'-'A'-'0'-'A'-'0'-'4'-STX-'0'-'C'-ETX-CHK- CR

The monitor replies the packet for confirmation as follows;

SOH-'0'-'0'-'A'-'B'-'0'-'6'-STX-'0'-'0'-'0'-'C'-ETX-CHK- CR

5.5.2 Get Timing Report and Timing reply.

The controller requests the monitor to report the displayed image timing.

STX	Command code		ETX
	'0'	'7'	

- Send "07" (30h, 37h) as Get Timing Report command.
- Complete "Get Timing Report" command packet as follows;

ASCII: 01h-30h-41h-30h-41h-30h-34h-02h-30h-37h-03h-CHK-0Dh

SOH-'0'-'A'-'0'-'A'-'0'-'4'-STX-'0'-'7'-ETX-CHK- CR

The monitor replies status as the following format;

STX	Command		SS		H Freq.				V Freq.				ETX
	'4'	'E'	Hi	Lo	MSB			LSB	MSB			LSB	

- SS: Timing status byte
 - Bit 7 = 1: Sync Frequency is out of range.
 - Bit 6 = 1: Unstable count
 - Bit 5-2 Reserved (Don't care)
 - Bit 1 1: Positive Horizontal sync polarity
0: Negative Horizontal sync polarity.
 - Bit 0 1: Positive Vertical sync polarity.
0: Negative Vertical sync polarity.
 - H Freq: Horizontal Frequency in unit 0.01kHz
 - V Freq: Vertical Frequency in unit 0.01Hz
- Ex.) When H Freq is '1'2'A'9' (31h, 32h, 41h, 39h), it means 47.77kHz.

5.5.3 NULL Message

STX	Command code		ETX
	'B'	'E'	

The NULL message returned from the monitor is used in the following cases;

- To tell the controller that the monitor does not have any answer to give to the host (not ready or not expected)
- A null message will be returned by the monitor if the "Start Proof of Play" command is sent and the monitor has already started Proof of Play.
- A null message will be returned by the monitor if the "Stop Proof of Play" command is sent and the monitor has not started Proof of Play.
- Complete "NULL Message" command packet as follows;
01h-30h-30h-41h-42h-30h-34h-02h-42h-45h-03h-CHK-0Dh
SOH-'0'-'0'-'A'-'B'-'0'-'4'-STX-'B'-'E'-ETX-CHK- CR

IV. Control Commands

6. Typical procedure example

The following is a sample of procedures to control the monitor, these are examples of "Get parameter", "Set parameter" and "Save current settings".

6.1. How to change the "Backlight" setting.

Step 1. The controller requests the Monitor to reply with the current brightness setting and capability to support this operation. (Get parameter)

Header	Message	Check code	Delimiter
SOH-'0'-Monitor ID-'0'-'C'-'0'-'6'	STX-'0'-'0'-'1'-'0'-ETX	BCC	CR

Header

SOH (01h): Start of Header
'0' (30h): Reserved
Monitor ID: Specify the Monitor ID from which you want to get a value.
Ex.) If Monitor ID is '1', specify 'A'.
'0' (30h): Message sender is the controller.
'C' (43h): Message type is "Get parameter command".
'0'-'6' (30h, 36h): Message length is 6 bytes.

Message

STX (02h): Start of Message
'0'-'0' (30h, 30h): Operation code page number is 0.
'1'-'0' (31h, 30h): Operation code is 10h (in the OP code page 0).
ETX (03h): End of Message

Check code

BCC: Block Check Code
Refer to the section 4.3 "Check code" for a BCC calculation.

Delimiter

CR (0Dh): End of packet

Step 2. The monitor replies with current Backlight setting and capability to support this operation.

Header	Message	Check code	Delimiter
SOH-'0'-'0'-Monitor ID-'D'-'1'-'2'	STX-'0'-'0'-'0'-'0'-'1'-'0'-'0'-'0'-'0'-'0'-'6'-'4'-'0'-'0'-'3'-'2'-ETX	BCC	CR

Header

SOH (01h): Start of Header
'0' (30h): Reserved
'0' (30h): Message receiver is the controller.
Monitor ID: Indicate a replying Monitor ID.
Ex.) When this byte is set to 'A', the replying Monitor ID is '1'.
'D' (44h): Message Type is "Get parameter reply".
'1'-'2' (31h, 32h): Message length is 18 bytes.

Message

STX (02h): Start of Message
'0'-'0' (30h, 30h): Result code. No error.
'0'-'0' (30h, 30h): Operation code page number is 0.
'1'-'0' (31h, 30h): Operation code is 10h (in the page 0).
'0'-'0' (30h, 30h): This operation is "Set parameter" type.
'0'-'0'-'6'-'4' (30h, 30h, 36h, 34h): Backlight max value is 100(0064h).
'0'-'0'-'3'-'2' (30h, 30h, 33h, 32h): Current Backlight setting is 50(0032h) .
ETX (03h): End of Message

Check code

BCC: Block Check Code
Refer to the section 4.3 "Check code" for a BCC calculation.

Delimiter

CR (0Dh): End of packet

Step 3. The controller request the monitor to change the Backlight setting

Header	Message	Check code	Delimiter
SOH-'0'-Monitor ID-'0'-'E'-'0'-'A'	STX-'0'-'0'-'1'-'0'-'0'-'0'-'5'-'0'-ETX	BCC	CR

Header

SOH (01h): Start of Header

'0' (30h): Reserved

Monitor ID: Specify the Monitor ID of which you want to change a setting.

Ex.) If Monitor ID is '1', specify 'A'.

'0' (30h): Message sender is the controller.

'E' (45h): Message Type is "Set parameter command".

'0'-'A' (30h, 41h): Message length is 10 bytes.

Message

STX (02h): Start of Message

'0'-'0' (30h, 30h): Operation code page number is 0.

'1'-'0' (31h, 30h): Operation code is 10h (in the page 0).

'0'-'0'-'5'-'0' (30h, 30h, 35h, 30h): Set Backlight setting 80(0050h).

ETX (03h): End of Message

Check code

BCC: Block Check Code

Refer to the section 4.3 "Check code" for a BCC calculation.

Delimiter

CR (0Dh): End of packet

Step 4. The monitor replies with a message for confirmation.

Header	Message	Check code	Delimiter
SOH-'0'-'0'- Monitor ID - 'F'-'1'-'2'	STX-'0'-'0'-'0'-'0'-'1'-'0'-'0'-'0'-'0'-'0'-'6'-'4'-'0'-'0'-'5'-'0'-ETX	BCC	CR

Header

SOH (01h): Start of Header

'0' (30h): Reserved

'0' (30h): Message receiver is the controller.

Monitor ID: Indicate a replying Monitor ID.

Ex.) When this byte is set to 'A', the replying Monitor ID is '1'.

'F' (46h): Message Type is "Set parameter reply".

'1'-'2' (31h, 32h): Message length is 18 bytes.

Message

STX (02h): Start of Message

'0'-'0' (30h, 30h): Result code. No error.

'0'-'0' (30h, 30h): Operation code page number is 0.

'1'-'0' (31h, 30h): Operation code is 10h (in the page 0).

'0'-'0' (30h, 30h): This operation is "Set parameter" type.

'0'-'0'-'6'-'4' (30h, 30h, 36h, 34h): Backlight max value is 100(0064h).

'0'-'0'-'5'-'0' (30h, 30h, 35h, 30h): Received a Backlight setting was 80(0050h) .

ETX (03h): End of Message

Check code

BCC: Block Check Code

Refer to the section 4.3 "Check code" for a BCC calculation.

Delimiter

CR (0Dh): End of packet

➤ Repeat Step 1 and Step 2, if you need to check the Backlight setting. (Recommended)

Step 5. Request the monitor to store the Backlight setting. (Save Current Settings Command)

Header	Message	Check code	Delimiter
SOH-'0'-Monitor ID- '0'-'A'-'0'-'4'	STX-'0'-'C'-ETX	BCC	CR

Header

SOH (01h): Start of Header

'0' (30h): Reserved

Monitor ID: Specify the Monitor ID which you want to store the setting.

Ex.) If Monitor ID is '1', specify 'A'.

'0' (30h): Message sender is the controller.

'A' (41h): Message type is "Command".

'0'-'4' (30h, 34h): Message length is 4 bytes.

Message

STX (02h): Start of Message

'0'-'C' (30h, 43h): Command code is 0Ch as "Save current settings".

ETX (03h): End of Message

Check code

BCC: Block Check Code

Refer to the section 4.3 "Check code" for a BCC calculation.

Delimiter

CR (0Dh): End of packet

6.2. How to read the measurement value of the built-in temperature sensors.

MultiSync P404/ P484/ P554/ V404/ V484/ V554 have three built-in temperature sensors. The controller can monitor inside temperatures by using those sensors with external control.

The following shows the procedure for reading the temperatures from the sensors.

Step 1. Select a temperature sensor which you want to read.

Header	Message	Check code	Delimiter
SOH-'0'-Monitor ID-'0'-'E'-'0'-'A'	STX-'0'-'2'-'7'-'8'-'0'-'0'-'0'-'1'-ETX	BCC	CR

Header

SOH (01h): Start of Header
 '0' (30h): Reserved
 Monitor ID: Specify the Monitor ID which you want to get a value.
 Ex.) If Monitor ID is '1', specify 'A'.
 '0' (30h): Message sender is the controller.
 'E' (45h): Message Type is "Set parameter command".
 '0'-'A' (30h, 41h): Message length is 10 bytes.

Message

STX (02h): Start of Message
 '0'-'2' (30h, 32h): Operation code page number is 2.
 '7'-'8' (37h, 38h): Operation code is 78h (on page 2).
 '0'-'0'-'0'-'1' (30h, 30h, 30h, 31h): Select the temperature sensor #1 (01h).
 00h: No meaning
 01h: Sensor #1
 02h: Sensor #2
 03h: Sensor #3
 ETX (03h): End of Message

Check code

BCC: Block Check Code
 Refer to the section 4.3 "Check code" for a BCC calculation.

Delimiter

CR (0Dh): End of packet

Step 2. The monitor replies for confirmation.

Header	Message	Check code	Delimiter
SOH-'0'-'0'-Monitor ID-'F'-'1'-'2'	STX-'0'-'0'-'0'-'2'-'7'-'8'-'0'-'0'-'0'-'3'-'0'-'0'-'0'-'1'-ETX	BCC	CR

Header

SOH (01h): Start of Header
 '0' (30h): Reserved
 '0' (30h): Message receiver is the controller.
 Monitor ID: Indicates a replying Monitor ID.
 Ex.) When this byte is set to 'A', the replying Monitor ID is '1'.
 'F' (46h): Message Type is "Set parameter reply".
 '1'-'2' (31h, 32h): Message length is 18 bytes.

Message

STX (02h): Start of Message
 '0'-'0' (30h, 30h): Result code. No error.
 '0'-'2' (30h, 32h): Operation code page number is 2.
 '7'-'8' (37h, 38h): Operation code is 78h (in the page 2).
 '0'-'0' (30h, 30h): This operation is "Set parameter" type.
 '0'-'0'-'0'-'3' (30h, 30h, 30h, 33h): Number of temperature sensors are 3 (0003h).
 '0'-'0'-'0'-'1' (30h, 30h, 30h, 31h): temperature sensor is #1.
 ETX (03h): End of Message

Check code

BCC: Block Check Code

Refer to the section 4.3 "Check code" for a BCC calculation.

Delimiter

CR (0Dh): End of packet

Step 3. The controller requests the monitor to send the temperature from the selected sensor.

Header	Message	Check code	Delimiter
SOH-'0'-Monitor ID-'0'-'C'-'0'-'6'	STX-'0'-'2'-'7'-'9'-ETX	BCC	CR

Header

SOH (01h): Start of Header

'0' (30h): Reserved

Monitor ID: Specify the Monitor ID which you want to get a value.

Ex.) If Monitor ID is '1', specify 'A'.

'0' (30h): Message sender is the controller.

'C' (43h): Message Type is "Get parameter".

'0'-'6' (30h, 36h): Message length is 6 bytes.

Message

STX (02h): Start of Message

'0'-'2' (30h, 32h): Operation code page number is 2.

'7'-'9' (37h, 39h): Operation code is 79h (in the page 2).

ETX (03h): End of Message

Check code

BCC: Block Check Code

Refer to the section 4.3 "Check code" for a BCC calculation.

Delimiter

CR (0Dh): End of packet

Step 4. The monitor replies a temperature of selected sensor.

Header	Message	Check code	Delimiter
SOH-'0'-'0'-Monitor ID-'D'-'1'-'2'	STX-'0'-'0'-'0'-'2'-'7'-'9'-'0'-'0'-'F'-'F'-'F'-'F'-'0'-'0'-'3'-'2'-ETX	BCC	CR

Header

SOH (01h): Start of Header

'0' (30h): Reserved

'0' (30h): Message receiver is the controller.

Monitor ID: Indicate a replying Monitor ID.

Ex.) When this byte is set to 'A', the replying Monitor ID is '1'.

'D' (44h): Message Type is "Get parameter reply".

'1'-'2' (31h, 32h): Message length is 18 bytes.

Message

STX (02h): Start of Message

'0'-'0' (30h, 30h): Result code. No error.

'0'-'2' (30h, 32h): Operation code page number is 2.

'7'-'9' (37h, 39h): Operation code is 79h (in the page 2).

'0'-'0' (30h, 30h): This operation is "Set parameter" type.

'F'-'F'-'F'-'F' (46h, 46h, 46h, 46h): Maximum value.

'0'-'0'-'3'-'2' (30h, 30h, 33h, 32h): The temperature is 25 degrees Celsius.

Readout value is 2's complement.

Temperature [Celsius]	Readout value	
	Binary	Hexadecimal
+125.0	0000 0000 1111 1010	00FAh
+ 25.0	0000 0000 0011 0010	0032h

+ 0.5	0000 0000 0000 0001	0001h
0	0000 0000 0000 0000	0000h
- 0.5	1111 1111 1111 1111	FFFFh
- 25.0	1111 1111 1100 1110	FFCEh
- 55.0	1111 1111 1001 0010	FF92h

ETX (03h): End of Message

Check code

BCC: Block Check Code

Refer to the section 4.3 "Check code" for a BCC calculation.

Delimiter

CR (0Dh): End of packet

6.3. Operation Code (OP code) Table

1) SPECTRAVIEW ENGINE Setting = OFF

	Item	OP code page	OP code	Parameter	Remarks	
INPUT	INPUT	00h	60h	0: No mean 1: VGA(RGB) 3: DVI 5: VIDEO 12(0Ch): YGA(YPbPr) 13(0Dh): OPTION 15(0Fh): DisplayPort1 16(10h): DisplayPort2 17(11h): HDMI1 18(12h): HDMI2 135(87h): MP 136(88h): COMPUTE MODULE	OP code page 11h, OP code 06h operation is same.	
PICTURE	PICTURE MODE	02h	1Ah	0: No mean 1: sRGB 3: HIGHBRIGHT 4: STANDARD 5: CINEMA 8: CUSTOM1 9: CUSTOM2	sRGB: PC mode only CINEMA: A/V mode only	
	BRIGTNNESS	BACKLIGHT	00h	10h	0: dark 100(64h): bright	
		BRIGHTNESS	00h	92h	0: dark 100(64h): bright	
	GAMMA CORRECTION	02h	68h	0: No mean 1: NATIVE 4: 2.2 8: 2.4 7: S GAMMA 5: DICOM SIM. 6: PROGRAMABLE1 13(0Bh): PROGRAMABLE2 14(0Ch): PROGRAMABLE3		
	COLOR	COLOR	02h	1Fh	0: pale 100(64h): deep	
		COLOR TEMPERATURE	00h	54h	0:2600K 74(4Ah):10000K	100K/step
		COLOR TEMPERATURE (CUSTOM)	00h	14h	9: 10000K 11(0Bh): CUSTOM	Select "CUSTOM" to adjust the R G B gain.
		R GAIN	00h	16h	0: Dark 255(FFh): Bright	
		B GAIN	00h	18h	0: Dark 255(FFh): Bright	
		G GAIN	00h	1Ah	0: Dark 255(FFh): Bright	

Item		OP code page	OP code	Parameter	Remarks
	COLOR CONTROL	00h	RED: 9Bh YELLOW: 9Ch GREEN: 9Dh CYAN: 9Eh BLUE: 9Fh MAGENTA: A0h	0: 100(64h):(center) 200(C8h):	
	HUE	00h	90h	0: purplish 100(64h): greenish	
	CONTRAST	00h	12h	0: low 100(64h): high	
	SHARPNESS	00h	8Ch	0: dull 24(18h): sharp	
ADJUST	AUTO SETUP	00h	1Eh	0: No mean 1: Execute	Momentary
	AUTO ADJUST	10h	B7h	0: No mean 1: OFF 2: ON	
	H POSITION	00h	20h	0: Left side Max.: Right side	Depends on a display timing
	V POSITION	00h	30h	0: Bottom side Max.: Top side	Depends on a display timing
	CLOCK	00h	0Eh	0: Max. :	
	PHASE	00h	3Eh	0: Max. :	
	H RESOLUTION	02h	50h	0: Low Max. : High	
	V RESOLUTION	02h	51h	0: Low Max.: High	
	COLOR SYSTEM	02h	21h	0: No mean 1: NTSC 2: PAL 3: SECAM 4: AUTO 5: 4.43NTSC 6: PAL-60	

	Item	OP code page	OP code	Parameter	Remarks
	INPUT RESOLUTION	02h	DAh	Input Resolution select 0: No mean 1: Item 1(always Auto) 2: Item 2 3: Item 3 4: Item 4 5: Item 5 Ex) Item 1= AUTO Item 2= -- / 1024x768 / 1400x1050 / 800x600 / 1280x960 Item 3= -- / 1280x768 / 1680x1050 / 1024x576 / 1600x900 / Item 4= -- / 1360x768 / -- / -- / -- Item 5= -- / 1366x768 -- / -- / --	
ASPECT	ASPECT	02h	70h	0: No mean 1: NORMAL 2: FULL 3: WIDE 4: ZOOM 6: DYNAMIC 7: 1:1	Wide: Dynamic A/V mode only
	ZOOM	11h	2Ch	0-89(59h): No mean 90(5Ah): 90% 91(5Bh): 91% 100(64h): 100% 300(12Ch): 300%	The following commands can also be used. OP code page 02h OP code 6Fh Parameter 0: No mean 1: 100% 2: 101% 201(C9h): 300%
	H ZOOM	11h	2Dh	0-89(59h): No mean 90(5Ah): 90% 91(5Bh): 91% 100(64h): 100% 300(12Ch): 300%	The following commands can also be used. OP code page 02h OP code 6Ch Parameter 0: No mean 1: 100% 2: 101% 201(C9h): 300%

	Item	OP code page	OP code	Parameter	Remarks	
	V ZOOM	11h	2Eh	0-89(59h): No mean 90(5Ah): 90% 91(5Bh): 91% 100(64h): 100% 300(12Ch): 300%	The following commands can also be used. OP code page 02h OP code 6Dh Parameter 0: No mean 1: 100% 2: 101% 201(C9h): 300%	
	H POS	02h	CCh	0: Left side 200(C8h): Right side		
	V POS	02h	CDh	0: Down side 200(C8h): Up side		
	ADVANCED	OVER SCAN	02h	E3h	0: No mean 1: OFF 2: ON	
		DEINTERLACE	02h	25h	0: No mean 1: Off 2: ON	
		ADAPTIVE CONTRAST	02h	8Dh	0: No mean 1: Off 2: LOW 4: High	
		NOISE REDUCTION	02h	26h	0: Off 3: High	Page02 OPcode20h also works as same.
		TELECINE	02h	23h	0: No mean 1: Off 2: Auto	
	ROTATION	IMAGE FLIP	02h	D7h	0: No mean 1: NONE 2: H FLIP 3: V FLIP 4: 180 ROTATE	
		OSD FLIP	10h	B8h	0: No mean 1: OFF 2: ON	
		SPECTRAVIEW ENGINE	11h	47h	0: No mean 1: Off 2: ON	
		RESET (PICTURE)	02h	CBh	0: No mean 2: Reset Picture category	Momentary
	AUDIO	VOLUME	00h	62h	0: whisper 100(64h): loud	
BALANCE		BALANCE	00h	93h	0: Left 30(1Eh): (Center) 60(3Ch): Right	
			00h	94h	0: No mean 1: MONAURAL 2: STEREO	
		SURROUND	02h	34h	0: No mean 1: OFF 2: ON	

Item		OP code page	OP code	Parameter	Remarks
EQUILIZER	TREBLE	00h	8Fh	0: Min. 6:(Center) 12(0Ch): Max.	
	BASS	00h	91h	0: Min. 6:(Center) 12(0Ch): Max.	
AUDIO INPUT		02h	2Eh	0: No mean 1: IN1 2: IN2 4: HDMI1 6: OPTION 7: DisplayPort1 8: DisplayPort2 10(0Ah): HDMI2 13(0Dh): MP 14(0Eh): COMPUTE MODULE	
MULTI PICTURE AUDIO		10h	80h	0: No mean 3: PICTURE1 4: PICTURE2	
LINE OUT		10h	81h	0: No mean 1: FIXED 2: VARIABLE	
AUDIO DELAY	AUDIO DELAY	10h	CAh	0: No mean 1: OFF 2: ON	
	DELAY TIME	10h	CBh	0: (small) 100(64h): (large)	
RESET (AUDIO)		02h	CBh	0: No mean 4: Reset Audio category	Momentary
SCHEDULE	ENABLE	02h	E5h	0: No mean 1: No.1 Enable 30(1Eh): No.30 Enable	
	DISABLE	02h	E6h	0: No mean 1: No.1 Disable 30(1Eh): No.30 Disable	
SCHEDULE SETTINGS				N/A	
HOLIDAY SETTINGS				N/A	
WEEKEND SETTINGS				N/A	
DATE & TIME		Refer to chapter 9			
DAYLIGHT SAVING		Refer to chapter 14			
OFF TIMER		02h	2Bh	0: Off 1: 1 hour 24(18h): 24 hour	1 hour/step
RESET (SCHEDULE)		02h	CBh	0: No mean 5: Reset Schedule category	Momentary

	Item	OP code page	OP code	Parameter	Remarks	
MULTI INPUT	KEEP MULTI PICTURE MODE	10h	82h	0: No mean 1: OFF 2: ON		
	MULTI PICTURE MODE	02h	72h	0: No mean 1: OFF 2: PIP 5: PBP		
	ACTIVE PICTURE	ACTIVE	11h	0Bh	0: No mean 1: PICTURE1 2: PICTURE2	
		ACTIVE FRAME	11h	0Dh	0: No mean 1: OFF 2: ON	
	INPUT SELECT	PICTURE1	11h	0Eh	0: No mean 1: VGA(RGB) 3: DVI 5: VIDEO 12(0Ch): YGA(YPbPr) 13(0Dh): OPTION	
		PICTURE2	11h	0Fh	15(0Fh): DisplayPort1 16(10h): DisplayPort2 17(11h): HDMI1 18(12h): HDMI2 135(87h): MP 136(88h): COMPUTE MODULE	
	PICTURE SIZE		10h	B9h	0(small) 80(large)	
	PICTURE POSITION	X	02h	74h	0: left 100(64h): right	
		Y	02h	75h	0: top 100(64h): bottom	
	ASPECT		10h	83h	0: No mean 1: NORMAL 2: FULL 6: EXPAND	
	TEXT TICKER	MODE	10h	08h	0: No mean 1: OFF 2: HORIZONTAL 3: VERTICAL	
		POSITION	10h	09h	0: Top/Left 100(64h): Bottom/Right	
		SIZE	10h	0Ah	0-1: Do not set. 2: Narrow(2/24) 8: Wide(8/24)	
		DETECT	10h	0Ch	0: No mean 1: AUTO 2: OFF	
		PICTURE1	11h	2Ah	0: No mean 1: VGA(RGB) 3: DVI 5: VIDEO 12(0Ch): YGA(YPbPr)	

Item		OP code page	OP code	Parameter	Remarks
	PICTURE2	11h	2Bh	13(0Dh): OPTION 15(0Fh): DisplayPort1 16(10h): DisplayPort2 17(11h): HDMI1 18(12h): HDMI2 135(87h): MP 136(88h): COMPUTE MODULE	
	INPUT DETECT	02h	40h	0: FIRST DETECT 1: LAST DETECT 2: NONE 3: VIDEO DETECT 4: CUSTOM DETECT	
CUSTOM DETECT	PRIORITY1	10h	2Eh	0: No mean 1: VGA(RGB) 3: DVI 5: VIDEO	
	PRIORITY2	10h	2Fh	12(0Ch): YGA(YPbPr) 13(0Dh): OPTION 15(0Fh): DisplayPort1 16(10h): DisplayPort2	
	PRIORITY3	10h	30h	17(11h): HDMI1 18(12h): HDMI2 135(87h): MP 136(88h): COMPUTE MODULE	
	INPUT CHANGE	10h	86h	0: No mean 1: NORMAL 2: QUICK 3: SUPER	When you set up "SUPER", please set up INPUT1 and INPUT2 first.
SUPER	INPUT1	10h	CEh	0: No mean 1: VGA(RGB) 3: DVI 5: VIDEO 12(0Ch): YGA(YPbPr) 13(0Dh): OPTION	
	INPUT2	10h	CFh	15(0Fh): DisplayPort1 16(10h): DisplayPort2 17(11h): HDMI1 18(12h): HDMI2 135(87h): MP 136(88h): COMPUTE MODULE	
TERMINAL SETTING	DVI MODE	02h	CFh	0: No mean 1: DVI-PC 2: DVI-HD	
	VGA MODE	10h	8Eh	0: No mean 1: RGB 2: YPbPr	
	DisplayPort	10h	F1h/F2h	Select target DPORT. (F1h) 0: No mean 1: DPORT 2: DPORT2 3: DPORT3 Read / Write status of target DPORT.(F2h) 0: No mean 1: 1.1a 2: 1.2	
	HDMI SIGNAL	10h	40h	0: No mean 1: EXPAND 2: RAW	

Item		OP code page	OP code	Parameter	Remarks	
	EQUALIZER	SLOT2	11h	90h	0: Low 7: High	
		DisplayPort1	11h	91h	0: Low 7: High	
	HDMI	11h	68h	0: No mean 1: MODE1 2: MODE2		
	VIDEO LEVEL	10h	40h	0: No mean 1: EXPAND 2: NORMAL 3: AUTO		
RESET (MULTI INPUT)		02h	CBh	0: No mean 6: Reset MULTI INPUT Category	Momentary	
OSD	LANGUAGE		00h	68h	0: No mean 1: ENGLISH 2: GERMAN 3: FRENCH 4: SPANISH 5: JAPANESE 6: ITALIAN 7: SWEDISH 9: RUSSIAN 14(0Eh): CHINESE	OSD Language
	MENU DISPLAY TIME		00h	FCh	0-1: Do not set. 2: 10s 3: 15s 48(30h): 240s	5sec/step
	OSD POSITION	X	02h	38h	0: Left 255(FFh): Right	
		Y	02h	39h	0: Down 255(FFh): Up	
	INFORMATION OSD		02h	3Dh	0: Disable information OSD 3-10(0Ah): OSD timer [seconds]	
	OSD TRANSPARENCY		02h	B8h	0: No mean 1: OFF 2: ON	
	OSD ROTATION		02h	41h	0: Landscape 1: Rotated	
	KEY GUIDE		11h	7Ah	0: No mean 1: OFF 2: ON	
	MEMO		10h	BAh	0: No mean 1: Display a Memo 2: Undisplay a Memo	
	INPUT NAME		Refer to chapter 17			
	NAME RESET					
	CLOSED CAPTION		10h	84h	0: No mean 1: OFF 2: CC1 3: CC2 4: CC3 5: CC4 6: TT1 7: TT2 8: TT3 9: TT4	

	Item	OP code page	OP code	Parameter	Remarks	
	RESET (OSD)	02h	CBh	0: No mean 7: Reset OSD category	Momentary	
MULTI DISPLAY	AUTO TILE MATRIX SETIP	Refer to chapter 18				
	SETTING COPY	Refer to Chapter 20				
	TILE MATRIX	H MONITOR	02h	D0h	0: No mean 1 10(0Ah)	Number of H-division
		V MONITOR	02h	D1h	0: No mean 1 10(0Ah)	Number of V-division
		POSITION	02h	D2h	0: No mean 1 100(64h)	
		TILE COMP	02h	D5h	0: No mean 1: NO 2: YES	
		ENABLE	02h	D3h	0: No mean 1: NO 2: YES	
	TILE MATRIX MEM	10h	4Ah	0: No mean 1: COMMON 2: INPUT		
	MONITOR ID	02h	3Eh	1-100:ID		
	GROUP ID	10h	7Fh	0: No assignment 1: Group A 2: Group B 3: Group AB 4: Group C 5: Group AC 1023(3FFh):Group ABCDEFGHIJ	Bit0:Group A Bit1:Group B Bit2:Group C Bit3:Group D Bit4:Group E Bit5:Group F Bit6:Group G Bit7:Group H Bit8:Group I Bit9:Group J	
	AUTO ID	Refer to chapter 16				
	AUTO ID RESET	Refer to chapter 16				
	RESET (MULTI DISPLAY)	02h	CBh	0: No mean 8: Reset Multi Display Category	Momentary	
	DISPLAY PROTECTION	POWER SAVE	Refer to Chapter 19			
POWER SAVE MESSAGE11h		11h	7Bh	0: No mean 1: OFF 2: ON		
FAN CONTROL		COOLING FAN	02h	7Dh	0: No mean 1: AUTO 2: ON	
		FAN SPEED	10h	3Fh	0: No mean 1: HIGH 2: LOW	

Item		OP code page	OP code	Parameter	Remarks	
	SENSOR1	10h	E0h/E1h	E0h: Set centigrade 0 - 65535(FFFFh) E1h: Set offset from max. value 0 - 10(0Ah)		
	SENSOR2	10h	E2h/E3h	E2h: Set centigrade 0 - 65535(FFFFh) E3h: Set offset from max. value 0 - 10(0Ah)		
	SENSOR3	10h	E4h/E5h	E4h: Set centigrade 0 - 65535(FFFFh) E5h: Set offset from max. value 0 - 10(0Ah)		
HEAT STATUS	FAN1/2/3	02h	7Ah /7Bh	Select target FAN. (7Ah) 0: No mean 1: FAN#1 2: FAN#2 3: FAN#3 Read status of target FAN.(7Bh) 0: OFF 1: ON 2: ERROR	Read Only	
	BACKLIGHT	Refer to Chapter 10 (Self-diagnosis status read)				
	TEMPERATURE SENSOR1/2/3	02h	79h	Return value is 2's complement. (0.5°C step)	Offset affects to a selected sensor. Select sensor (Page02h OPcode78h) 1 : SENSOR #1 2 : SENSOR #2 3 : SENSOR #3	
SCREEN SAVER	GAMMA	02h	DBh	0: No mean 1: OFF 2: ON		
	BACKLIGHT	02h	DCh	0: No mean 1: OFF 2: ON		
	MOTION	INTERVAL	02h	DDh	0: OFF(0s) 90(5Ah): 900s	10s/step
		ZOOM	10h	35h	0 : 95% 5 : 100% 10(0Ah) : 105%	
SIDE BORDER COLOR		02h	DFh	0: Black 100(64h): White		
POWER ON DELAY	DELAY TIME	10h	CBh	0: (small) 100(64h): (large)		
	LINK TO ID	10h	BCh	0: No mean 1: OFF 2: ON		
RESET (DISPLAY PROTECTION)		02h	CBh	0: No mean 9: Reset Display Protection category	Momentary	

	Item	OP code page	OP code	Parameter	Remarks	
CONTROL	IP ADDRESS SETTING			N/A		
	CHANGE PASSWORD			N/A		
	SECURITY	Refer to Chapter 21				
	IR LOCK SETTING	MODE SELECT	10h	D4h	0: No mean 1: UNLOCK 2: ALL LOCK 3: CUSTOM LOCK	The following commands can also be used. OP code page 02h OP code 3Fh Parameter 0: No mean 1: NORMAL 4: LOCK
		POWER	10h	D5h	0: No mean 1: UNLOCK 2: LOCK	
		VOLUME	10h	D6h	0: No mean 1: UNLOCK 2: LOCK	
		MIN VOL	10h	D7h	0 (whisper) 100(64h) (laud)	
		MAX VOL	10h	D8h	0 (whisper) 100(64h) (laud)	
		INPUT	10h	D9h	0: No mean 1: UNLOCK 2: LOCK	
		UNLOCK SELECT	10h	DAh	0: No mean 1: VGA (RGB) 3: DVI 5: VIDEO	
				DBh	12(0Ch): YGA(YPbPr) 13(0Dh): OPTION 15(0Fh): DisplayPort1 16(10h): DisplayPort2	
				DCh	17(11h): HDMI1 18(12h): HDMI2 135(87h): MP 136(88h): COMPUTE MODULE	
	CHANNEL	10h	D9h	0: No mean 1: UNLOCK 2: LOCK		
	KEY LOCK SETTING	MODE SELECT	11h	6Ah	0: No mean 1: UNLOCK 2: ALL LOCK 3: CUSTOM LOCK	
		POWER	11h	6Bh	0: No mean 1: UNLOCK 2: LOCK	
		VOLUME	11h	6Ch	0: No mean 1: UNLOCK 2: LOCK	
		MIN VOL	11h	6Dh	0 (whisper) 100(64h) (laud)	
		MAX VOL	11h	6Eh	0 (whisper) 100(64h) (laud)	
		INPUT	11h	6Fh	0: No mean 1: UNLOCK 2: LOCK	

Item	OP code page	OP code	Parameter	Remarks				
CHANNEL	10h	D9h	0: No mean 1: UNLOCK 2: LOCK					
DDC/CI	10h	BEh	0: No mean 1: OFF 2: ON					
PING			N/A					
IP ADDRESS RESET			N/A					
AUTO DIMMING	AUTO BRIGHTNESS		02h	2Dh	0: OFF 1: ON			
	ROOM LIGHT SENSING	MODE		10h	C8h	0: No mean 1: OFF 2: MODE1 3: MODE2		
		BACKLIGHT SETTING	MAX LIMIT		10h	C9h	0 - 100(64h)	
			IN BRIGHT		10h	33h	0 - 100(64h)	
			IN DARK		10h	34h	0 - 100(64h)	
			SENSING LUX		02h	B4h	Current Illuminance read	Read only
	HUMAN SENSING	MODE		10h	75h	0: No mean 1: DISABLE 2: AUTO OFF 4: CUSTOM		
		BACKLIGHT	ON/OFF		10h	DDh	0: No mean 1: Off 2: On	
			BACKLIGHT		10h	C6h	0: dark 100(64h): light	
		VOLUME	ON/OFF		10h	DEh	0: No mean 1: Off 2: On	
			VOLUME		10h	C7h	0: whisper 100(64h): loud	
		INPUT SELECT	ON/OFF		10h	DFh/D0h	0: No mean 1: Off 2: On	
			INPUT		10h	D0h	0: No mean 1: VGA(RGB) 3: DVI 5: VIDEO 12(0Ch): YGA(YPbPr) 13(0Dh): OPTION 15(0Fh): DisplayPort1 16(10h): DisplayPort2 17(11h): HDMI1 18(12h): HDMI2 135(87h): MP 136(88h): COMPUTE MODULE	
			WAITING TIME		10h	78h	30(1Eh): short 600(258h): long *1step: 1sec.	

	Item	OP code page	OP code	Parameter	Remarks		
	POWER INDICATOR	POWER INDICATOR	02	BEh	0: No mean 1: Off 2: On		
		SCHEDULE INDICATOR	11h	71h	0: No mean 1: Off 2: On		
	INTELLI WIRELESS DATA		10h	ECh	0: No mean 1: OFF 2: ON		
	USB	TOUCH POWER	11h	72h	0: No mean 1: OFF 2: ON		
		EXTERNAL CONTROL	11h	73h	0: No mean 1: OFF 2: ON		
		PC SOURCE	11h	74h	0: No mean 1: AUTO 2: EXTERNAL PC 3: OPTION 4: C MODULE		
		USB POWER	11h	75h	0: No mean 1: ON 2: AUTO		
	CEC	CEC	11h	76h	0: No mean 1: OFF 2: ON		
		AUTO TURN OFF	11h	77h	0: No mean 1: NO 2: YES		
		AUDIO RECEIVER	11h	78h	0: No mean 1: NO 2: YES		
		SEARCH DEVICE	11h	79h	0: No mean 1: NO 2: YES		
	RESET (CONTROL)		02h	CBh	0: No mean 12(0Ch): Reset Control Category	Momentary	
	OPTION	AUDIO		10h	B0h	0: No mean 1: ANALOG 2: DIGITAL	
		INTERNAL PC	OFF WARNING	10h	C0h	0: No mean 1: OFF 2: ON	
			AUTO OFF	10h	C1h	0: No mean 1: OFF 2: ON	
START UP PC			10h	C2h	0: No mean 1: Execute		
FORCE QUIT			10h	C3h	0: No mean 1: Execute		
SLOT2 CH SETTING		11h	62h	0: No mean 1: AUTO 2: CH1 3: CH2			

	Item	OP code page	OP code	Parameter	Remarks		
	SLOT2 CH SELECT	11h	63h	0: No mean 1: TDMS 2: DisplayPort			
	RESET (OPTION)	02h	CBh	0: No mean 10(0Ah): Option Category			
SYSTEM	MONITOR INFORMATION	MODEL NAME		Refer to chapter 11			
		SERIAL		Refer to chapter 11			
		CARBON SAVINGS	10h	10h (g) /11h (kg)	0 - 999(3E7h)(g) 0 - 65535(FFFFh)(kg)	Read Only	
		CARBON USAGE	10h	26h (g) /27h (kg)	0 - 999(3E7h)(g) 0 - 65535(FFFFh)(kg)	Read Only	
		FIRMWARE	Refer to chapter 15				
		MAC ADDRESS	Refer to Chapter 22				
		FACTORY RESET	02h	CBh	0: No mean 1: Factory Reset	Momentary	
COMPUTE MODULE	POWER	POWER SUPPLY		11h	7Ch	0: No mean 1: OFF 2: ON	
		AUTO POWER ON		11h	7Dh	0: No mean 1: DISABLE 2: ENABLE	
	SERVICE MENU	SETTING LOCK		Refer to Chapter 27			
			USB BOOT MODE	11h	7Eh	0: No mean 1: DISABLE 2: ENABLE	It can be used by turning OFF SETTING LOCK using SETTING LOCK command.
			IR SIGNAL	11h	7Fh	0: No mean 1: DISABLE 2: ENABLE	
			MONITOR CONTROL	11h	80h	0: No mean 1: DISABLE 2: ENABLE	
			SHUTDOWN SIGNAL	11h	81h	0: No mean 1: DISABLE 2: ENABLE	
			POWER OFF DELAY	11h	82h	30(1Eh): short 600(258h): long *1step: 1sec.	
		CHANGE PASSWORD			N/A		
	Other	MUTE		00h	8Dh	0: UNMUTE (Set only) 1: MUTE 2: UNMUTE	
SCREEN MUTE		10h	B6h	0: No mean 1: SCREEN MUTE ON 2: SCREEN MUTE OFF			
MTS		02h	2Ch	0: No mean 1: Main 2: Sub 3: Main + Sub	This operation requires supported option TV tuner.		
SOUND		02h	34h	0: No mean 1: Off 2: ON	Same as 'SURROUND'		

Item	OP code page	OP code	Parameter	Remarks
STILL CAPTURE	02h	76h	0: OFF 1: CAPTURE	Momentary
SIGNAL INFORMATION	02h	EAh	0: No mean 1: OFF 2: ON	
TV-CHANNEL UP/DOWN	00h	8Bh	0: No mean 1: UP 2: DOWN	This operation requires supported option TV tuner.

2) SPECTRAVIEW ENGINE Setting = ON

Item	OP code page	OP code	Parameter	Remarks	
PICTURE	PIC.MODE	02h	1Ah	0: No mean 13(0Dh): SVE-1 SETTING 14(0Eh): SVE-2 SETTING 15(0Fh): SVE-3 SETTING 16(10h): SVE-4 SETTING 17(11h): SVE-5 SETTING	
	PRESET	10h	51h	0: No mean 1: sRGB 2: Adobe RGB SIM 3: DCI SIM 4: REC-Bt709 5: HIGHBRIHGT 6: FULL 7: DICOM SIM 8: PROGRAMMABLE1 9: PROGRAMMABLE2 10(0Ah): PROGRAMMABLE3 11(0Bh): PROGRAMMABLE4 12(0Ch): PROGRAMMABLE5 13(0Dh): eciRGB v2	
	LUMINANCE	02h	B3h	0(0%): Dark 600(0258h)(100%): Bright Note: Conversion equation Value = (OSD Value/100) *(600-40)+40	
	BLACK	10h	54h	1: 0.1(MIN) 50(32h): 5.0(MAX)	
	GAMMA	02h	68h	0: No mean 5: DICOM SIM. 9: CST 11(0Bh): sRGB 12(0Ch): L STAR	
	CUSTOM VALUE	02h	E8h	0: 0.5(MIN) 350(015Eh): 4.0(MAX)	
	WHITE	00h	54h	0:2600K 74(4Ah):10000K	
		00h	14h	2: NAVIVE 11(0Bh): CUSTOM	
	WHITE x	10h	52h	250(00FAh): 0.250 480(01E0h): 0.480	

Item	OP code page	OP code	Parameter	Remarks
WHITE y	10h	53h	250(00FAh): 0.250 480(01E0h): 0.480	
RED x	10h	55h	550(0226h): 0.550 800(0320h): 0.800	
RED y	10h	56h	200(00C8h): 0.200 400(0190h): 0.400	
GREEN x	10h	57h	100(0064h): 0.100 350(015Eh): 0.350	
GREEN y	10h	58h	500(01F4h): 0.500 900(0384h): 0.900	
BLUE x	10h	59h	0: 0.000 250(00FAh): 0.250	
BLUE y	10h	5Ah	0: 0.000 150(0096h): 0.150	
COLOR VISION EMU	10h	5Bh	0: No mean 1: OFF 2: P 3: D 4: T 5: GRAY	
UNIFORMITY	02h	FFh	0: OFF 5	
METAMERISM	10h	5Ch	0: No mean 1: OFF 2: ON	

7. Power control procedure

7.1 Power status read

- 1) The controller requests the monitor to reply a current power status.

Header	Message	Check code	Delimiter
SOH-'0'-Monitor ID-'0'-'A'-'0'-'6'	STX-'0'-'1'-'D'-'6'-ETX	BCC	CR

Header

SOH (01h): Start of Header
 '0' (30h): Reserved
 Monitor ID: Specify the Monitor ID from which you want to get status.
 Ex.) If Monitor ID is '1', specify 'A'.
 '0' (30h): Message sender is the controller.
 'A' (41h): Message Type is "Command".
 '0'-'6' (30h, 36h): Message length is 6 bytes.

Message

STX (02h): Start of Message
 '0'-'1'-'D'-'6': Get power status command.
 ETX (03h): End of Message

Check code

BCC: Block Check Code
 Refer to the section 4.3 "Check code" for a BCC calculation.

Delimiter

CR (0Dh): End of packet

- 2) The monitor returns with the current power status.

Header	Message	Check code	Delimiter
SOH-'0'-'0'-Monitor ID-'B'-'1'-'2'	STX-'0'-'2'-'0'-'0'-'D'-'6'-'0'-'0'-'0'-'0'-'0'-'4'-'0'-'0'-'0'-'1'-ETX	BCC	CR

Header

SOH (01h): Start of Header
 '0' (30h): Reserved
 '0' (30h): Message receiver is the controller.
 Monitor ID: Indicate a replying Monitor ID.
 Ex.) When this byte is set to 'A', the replying Monitor ID is '1'.
 'B' (42h): Message Type is "Command reply".
 '1'-'2' (31h, 32h): Message length is 18 bytes.

Message

STX (02h): Start of Message
 '0'-'2' (30h, 32h): Reserved data
 '0'-'0' (30h, 30h): Result code
 00: No Error.
 01: Unsupported.
 'D'-'6' (44h, 36h): Display power mode code
 '0'-'0' (30h, 30h): Parameter type code is "Set parameter".
 '0'-'0'-'0'-'4' (30h, 30h, 30h, 34h): Power mode is 4 types.
 '0'-'0'-'0'-'1' (30h, 30h, 30h, 31h): Current power mode
 <Status>
 0001: ON
 0002: Stand-by (power save)
 0003: Suspend (power save)
 0004: OFF (same as IR power off)
 ETX (03h): End of Message

Check code

BCC: Block Check Code
 Refer to the section 4.3 "Check code" for a BCC calculation.

Delimiter
CR (0Dh): End of packet

7.2 Power control

1) The controller requests the monitor to control monitor power.

Header	Message	Check code	Delimiter
SOH-'0'-Monitor ID-'0'-'A'-'0'-'C'	STX-'C'-'2'-'0'-'3'-'D'-'6'-'0'-'0'-'0'-'1'-ETX	BCC	CR

Header

SOH (01h): Start of Header
 '0' (30h): Reserved
 Monitor ID: Specify the Monitor ID which you want to change a setting.
 Ex.) If Monitor ID is '1', specify 'A'.
 '0' (30h): Message sender is the controller.
 'A' (41h): Message type is "Command".
 '0'-'C' (30h, 43h): Message length is 12 bytes.

Message

STX (02h): Start of Message
 'C'-'2'-'0'-'3'-'D'-'6' (43h, 32h, 30h, 33h, 44h, 36h): power control command
 '0'-'0'-'0'-'1' (30h, 30h, 30h, 31h): Power mode
 0001: ON
 0002, 0003: Do not set.
 0004: OFF (same as the power off by IR)

ETX (03h): End of Message

Check code

BCC: Block Check Code
 Refer to the section 4.3 "Check code" for a BCC calculation.

Delimiter

CR (0Dh): End of packet

2) The monitor replies a data for confirmation.

Header	Message	Check code	Delimiter
SOH-'0'-'0'-Monitor ID-'B'-'0'-'E'	STX-'0'-'0'-'C'-'2'-'0'-'3'-'D'-'6'-'0'-'0'-'0'-'1'-ETX	BCC	CR

Header

SOH (01h): Start of Header
 '0' (30h): Reserved
 '0' (30h): Message receiver is the controller.
 Monitor ID: Indicate a replying Monitor ID.
 Ex.) When this byte is set to 'A', the replying Monitor ID is '1'.
 'B' (42h): Message type is "Command reply".
 'N'-'N': Message length
 Note.) The maximum data length that can be written to the monitor at a time is 32bytes.
 Ex.) The byte data 20h is encoded as ASCII characters '2' and '0' (32h and 30h).

Message

STX (02h): Start of Message
 '0'-'0' (30h, 30h): Result code. No error.
 'C'-'2', '0'-'3'-'D'-'6' (43h, 32h, 30h, 33h, 44h, 36h): power control reply command
 > The monitor replies same as power control command to the controller.
 '0'-'0'-'0'-'1' (30h, 30h, 30h, 31h): Power mode
 0001: ON
 0002, 0003: Do not set.
 0004: OFF (same as the power off by IR)

ETX (03h): End of Message

Check code

BCC: Block Check Code

Refer to the section 4.3 "Check code" for a BCC calculation.

Delimiter

CR (0Dh): End of packet

8. Asset Data read and write

MultiSync P404/ P484/ P554/ V404/ V484/ V554 have the area for to store user's asset data of up to 64bytes.

8.1 Asset Data Read Request and reply

This command is used in order to read Asset Data.

1) The controller requests the monitor to reply with Asset data.

Header	Message	Check code	Delimiter
SOH-'0'-Monitor ID-'0'-'A'-'0'-'A'	STX-'C'-'0'-'0'-'B'-'0'-'0'-'2'-'0'-ETX	BCC	CR

Header

SOH (01h): Start of Header
 '0' (30h): Reserved
 Monitor ID: Specify the Monitor ID from which you want to get data.
 Ex.) If Monitor ID is '1', specify 'A'.
 '0' (30h): Message sender is the controller.
 'A' (41h): Message type is "Command".
 '0'-'A' (30h, 41h): Message length is 10 bytes.

Message

STX (02h): Start of Message
 'C'-'0'-'0'-'B' (43h, 30h, 30h, 42h): Asset read request command.
 '0'-'0' (30h, 30h): Offset data from top of the Asset data.
 At first set 00h: Read data from the top of Asset data area.
 '2'-'0' (32h, 30h): Read out data length is 32bytes.
 Secondly set 20h: Read data from the 32bytes offset point in the Asset data area.
 Maximum readout length is 32bytes at a time.
 ETX (03h): End of Message

Check code

BCC: Block Check Code
 Refer to the section 4.3 "Check code" for a BCC calculation.

Delimiter

CR (0Dh): End of packet

2) The monitor replies Asset data to the controller.

Header	Message	Check code	Delimiter
SOH-'0'-'0'-'0'-'Monitor ID-'B'-'N-N	STX-'C'-'1'-'0'-'B'-'Data(0)-Data(1)---Data(N)-ETX	BCC	CR

Header

SOH (01h): Start of Header
 '0' (30h): Reserved
 '0' (30h): Message receiver is the controller.
 Monitor ID: Indicate a replying Monitor ID.
 Ex.) When this byte is set to 'A', the replying Monitor ID is '1'.
 'B' (42h): Message type is "Command reply"
 N-N: Message length
 Note.) This length includes STX and ETX.

Message

STX (02h): Start of Message
 'C'-'1'-'0'-'B' (43h, 31h, 30h, 42h): Asset read reply command
 Data(0) - Data(N): Returned Asset data
 Ex.) When Data(n) is 1234h, replying data is (31h 32h, 33h, 34h).
 ETX (03h): End of Message

Check code

BCC: Block Check Code
 Refer to the section 4.3 "Check code" for a BCC calculation.

Delimiter

CR (0Dh): End of packet

8.2 Asset Data write

This command is used in order to write Asset Data.

1) The controller requests the monitor to write Asset data.

Header	Message	Check code	Delimiter
SOH-'0'-Monitor ID-'0'-'A'-N-N	STX-'C'-'0'-'0'-'E'-'0'-'0'-Data(0)-Data(1)---Data(N)-ETX	BCC	CR

Header

SOH (01h): Start of Header

'0' (30h): Reserved

Monitor ID: Specify the Monitor ID in which you want to write data.

Ex.) If Monitor ID is '1', specify 'A'.

'0' (30h): Message sender is the controller.

'A' (41h): Message type is "Command".

N-N: Message length

Note.) The maximum data length that can be written to the monitor at a time is 32bytes.

Message

STX (02h): Start of Message

'C'-'0'-'0'-'E' (43h, 30h, 30h, 45h): Asset Data writes command

'0'-'0'(30h, 30h): Offset address from top of Asset data.

00h : Write data from top of the Asset data area.

Data(0) -- Data(N): Asset data. The data must be ASCII characters strings.

ETX (03h): End of Message

Check code

BCC: Block Check Code

Refer to the section 4.3 "Check code" for a BCC calculation.

Delimiter

CR (0Dh): End of packet

2) The monitor replies a data for confirmation.

Header	Message	Check code	Delimiter
SOH-'0'-'0'-Monitor ID-'B'-N-N	STX-'0'-'0'-'C'-'0'-'0'-'E'-'0'-'0'-Data(0)-Data(1)---Data(N)-ETX	BCC	CR

Header

SOH (01h): Start of Header

'0' (30h): Reserved

'0' (30h): Message receiver is the controller.

Monitor ID: Indicate a replying Monitor ID.

Ex.) When this byte is set to 'A', the replying Monitor ID is '1'.

'B' (42h): Message type is "Command reply".

N-N: Message length

Note.) The maximum data length that can be written to the monitor at a time is 32bytes.

Message

STX (02h): Start of Message

'0'-'0': Result code. No error.

'C'-'0'-'0'-'E' (43h, 30h, 30h, 45h): Asset Data write command

'0'-'0'(30h, 30h): Offset address from top of Asset data.

00h : Write data into from top of the Asset data area.

Data(0) -- Data(N): Asset data. The data must be ASCII characters strings.

ETX (03h): End of Message

Check code

BCC: Block Check Code

Refer to the section 4.3 "Check code" for a BCC calculation.

Delimiter

CR (0Dh): End of packet

9. Date & Time read and write

9.1 Date & Time Read

This command is used in order to read the setting of Date & Time.

- 1) The controller requests the monitor to reply with the Date & Time.

Header	Message	Check code	Delimiter
SOH-'0'-Monitor ID-'0'-'A'-'0'-'6'	STX-'C'-'2'-'1'-'1'-ETX	BCC	CR

Header

SOH (01h): Start of Header

'0' (30h): Reserved

Monitor ID: Specify the Monitor ID of which you want to get status.
Ex.) If Monitor ID is '1', specify 'A'.

'0' (30h): Message sender is the controller.

'A' (41h): Message type is "Command".

'0'-'6'(30h, 36h): Message length

Message

STX (02h): Start of Message

'C'-'2'-'1'-'1' (43h, 32h, 31h, 31h): Date & time read request command.

ETX (03h): End of Message

Check code

BCC: Block Check Code

Refer to the section 4.3 "Check code" for a BCC calculation.

Delimiter

CR (0Dh): End of packet

- 2) The monitor replies Date & Time to the controller.

Header	Message	Check code	Delimiter
SOH-'0'-'0'-Monitor ID-'B'-'1'-'4'	STX-'C'-'3'-'1'-'1'- YY-MM-DD-WW-HH-MN-DS-ETX	BCC	CR

Header

SOH (01h): Start of Header

'0' (30h): Reserved

'0' (30h): Message receiver is the controller

Monitor ID: Indicate a replying Monitor ID

Ex.) When this byte is set to 'A', the replying Monitor ID is '1'.

'B' (42h): Message type is "Command reply"

'1'-'4'(31h, 34h): Message length

Message

STX (02h): Start of Message

'C'-'3'-'1'-'1' (43h, 33h, 31h, 31h): Date & Time read reply command

'YY'-'MM'-'DD'-'WW'-'HH'-'MN'-'DS': Date & Time data

YY: Year (offset 2000)

'0'-'0'(30h, 30h): 2000

|

'6'-'3'(36h, 33h): 2099 (99 = 63h)

MM: Month

'0'-'1'(30h, 31h): January

|

'0'-'C'(30h, 43h): December

DD: Day

'0'-'1'(30h, 31h): 1

|

'1'-'E'(31h, 45h): 30(=1Eh)

'1'-'F'(31h, 46h): 31(=1Fh)

WW: weekdays
'0'-'0'(30h, 30h): Sunday
'0'-'1'(30h, 31h): Monday
'0'-'2'(30h, 32h): Tuesday
'0'-'3'(30h, 33h): Wednesday
'0'-'4'(30h, 34h): Thursday
'0'-'5'(30h, 35h): Friday
'0'-'6'(30h, 36h): Saturday

HH: Hours
'0'-'0'(30h, 30h): 0
|
'1'-'7'(31h, 37h): 23 (=17h)

MN: Minutes
'0'-'0'(30h, 30h): 0
|
'3'-'B'(33h, 42h): 59 (=3Bh)

DS: Daylight saving (Summer time)
'0'-'0'(30h, 30h): NO
'0'-'1'(30h, 31h): YES

ETX (03h): End of Message

Check code

BCC: Block Check Code

Refer to the section 4.3 "Check code" for a BCC calculation.

Delimiter

CR (0Dh): End of packet

9.2 Date & Time Write

This command is used in order to write the setting of the Date & Time.

1) The controller requests the monitor to write Date & Time.

Header	Message	Check code	Delimiter
SOH-'0'-Monitor ID-'0'-'A'-'1'-'2'	STX-'C'-'2'-'1'-'2'- YY-MM-DD-WW-HH-MN-DS-ETX	BCC	CR

Header

SOH (01h): Start of Header
 '0' (30h): Reserved
 Monitor ID: Specify the Monitor ID of which you want to change the setting.
 Ex.) If Monitor ID is '1', specify 'A'.
 '0' (30h): Message sender is the controller.
 'A' (41h): Message type is "Command".
 '1'-'2'(31h, 32h): Message length

Message

STX (02h): Start of Message
 'C'-'2'-'1'-'2' (43h, 32h, 31h, 32h): Date & Time write command
 'YY'-'MM'-'DD'-'WW'-'HH'-'MN'-'DS': Date & Time data
 YY: Year (offset 2000)
 '0'-'0'(30h, 30h): 2000
 |
 '6'-'3'(36h, 33h): 2099 (99 = 63h)

 MM: Month
 '0'-'1'(30h, 31h): JANUARY
 |
 '0'-'C'(30h, 43h): DECEMBER

 DD: Day
 '0'-'1'(30h, 31h): 1
 |
 '1'-'E'(31h, 45h): 30(=1Eh)
 '1'-'F'(31h, 46h): 31(=1Fh)

 WW: weekdays
 '0'-'0'(30h, 30h): SUNDAY
 '0'-'1'(30h, 31h): MONDAY
 '0'-'2'(30h, 32h): TUESDAY
 '0'-'3'(30h, 33h): WEDNESDAY
 '0'-'4'(30h, 34h): THURSDAY
 '0'-'5'(30h, 35h): FRIDAY
 '0'-'6'(30h, 36h): SATURDAY

 HH: Hours
 '0'-'0'(30h, 30h): 0
 |
 '1'-'7'(31h, 37h): 23 (=17h)

 MN: Minutes
 '0'-'0'(30h, 30h): 0
 |
 '3'-'B'(33h, 42h): 59 (=3Bh)

 DS: Daylight saving (Summer time)
 '0'-'0'(30h, 30h): NO
 '0'-'1'(30h, 31h): YES

ETX (03h): End of Message

Check code

BCC: Block Check Code
 Refer to the section 4.3 "Check code" for a BCC calculation.

Delimiter

CR (0Dh): End of packet

2) The monitor replies a data for confirmation.

Header	Message	Check code	Delimiter
SOH-'0'-'0'-Monitor ID-'B'-'1'-'6'	STX-'C'-'3'-'1'-'2'-ST-YY-MM-DD-WW-HH-MN-DS-ETX	BCC	CR

Header

SOH (01h): Start of Header

'0' (30h): Reserved

'0' (30h): Message receiver is the controller.

Monitor ID: Indicate a replying Monitor ID.

Ex.) When this byte is set to 'A', the replying Monitor ID is '1'.

'B' (42h): Message type is "Command reply".

'1'-'6'(31h, 36h): Message length

Message

STX (02h): Start of Message

'C'-'3'-'1'-'2' (43h, 33h, 31h, 32h): Date & Time write reply command

ST: Date & Time Status command

'0'-'0'(30h, 30h): No error

'0'-'1'(30h, 31h): Error

'YY'-'MM'-'DD'-'WW'-'HH'-'MN'-'DS': Date & Time data

YY: Year (offset 2000)

'0'-'0'(30h, 30h): 2000

|

'6'-'3'(36h, 33h): 2099 (99 = 63h)

MM: Month

'0'-'1'(30h, 31h): JANUARY

|

'0'-'C'(30h, 43h): DECEMBER

DD: Day

'0'-'1'(30h, 31h): 1

|

'1'-'E'(31h, 45h): 30(=1Eh)

'1'-'F'(31h, 46h): 31(=1Fh)

WW: weekdays

'0'-'0'(30h, 30h): SUNDAY

'0'-'1'(30h, 31h): MONDAY

'0'-'2'(30h, 32h): TUESDAY

'0'-'3'(30h, 33h): WEDNESDAY

'0'-'4'(30h, 34h): THURSDAY

'0'-'5'(30h, 35h): FRIDAY

'0'-'6'(30h, 36h): SATURDAY

HH: Hours

'0'-'0'(30h, 30h): 0

|

'1'-'7'(31h, 37h): 23 (=17h)

MN: Minutes

'0'-'0'(30h, 30h): 0

|

'3'-'B'(33h, 42h): 59 (=3Bh)

DS: Daylight saving (Summer time)

'0'-'0'(30h, 30h): NO

'0'-'1'(30h, 31h): YES

ETX (03h): End of Message

Check code

BCC: Block Check Code

Refer to the section 4.3 "Check code" for a BCC calculation.

Delimiter

CR (0Dh): End of packet

10. Self diagnosis

10.1 Self-diagnosis status read

This command is used in order to read the Self-diagnosis status.

- 1) The controller requests the monitor to read Self-diagnosis status.

Header	Message	Check code	Delimiter
SOH-'0'-Monitor ID-'0'-'A'-'0'-'4'	STX-'B'-'1'-ETX	BCC	CR

Header

SOH (01h): Start of Header
 '0' (30h): Reserved
 Monitor ID: Specify the Monitor ID which you want to get status.
 Ex.) If Monitor ID is '1', specify 'A'.
 '0' (30h): Message sender is the controller.
 'A' (41h): Message type is "Command".
 '0'-'4' (30h, 34h): Message length

Message

STX (02h): Start of Message
 'B'-'1' (42h, 31h): Self-diagnosis command
 ETX (03h): End of Message

Check code

BCC: Block Check Code
 Refer to the section 4.3 "Check code" for a BCC calculation.

Delimiter

CR (0Dh): End of packet

- 2) The monitor replies a result of the self-diagnosis.

Header	Message	Check code	Delimiter
SOH-'0'-'0'-Monitor ID-'B'-N-N	STX-'A'-'1'-ST(0)-ST(1) -----ST(n)-ETX	BCC	CR

Header

SOH (01h): Start of Header
 '0' (30h): Reserved
 '0' (30h): Message receiver is the controller.
 Monitor ID: Indicate a replying Monitor ID.
 Ex.) When this byte is set to 'A', the replying Monitor ID is '1'.
 'B' (42h): Message type is "Command reply".
 N-N: Message length
 Note.) The maximum data length that can be written to the monitor at a time is 32bytes.
 Ex.) The byte data 20h is encoded as ASCII characters '2' and '0' (34h and 30h).

Message

STX (02h): Start of Message
 'A'-'1' (41h, 31h): Application Test Report reply command
 ST: Result of self-tests
 '0'-'0' (30h, 30h):00: Normal
 '7'-'0' (37h, 30h):70: Standby-power +3.3V abnormality
 '7'-'1' (37h, 31h):71: Standby-power +5V abnormality
 '7'-'2' (37h, 32h):72: Panel-power +12V abnormality
 '7'-'8' (37h, 38h):78: Inverter power/Option slot2 power +24V Abnormality
 '8'-'0' (38h, 30h):80: Cooling fan-1 abnormality
 '8'-'1' (38h, 31h):81: Cooling fan-2 abnormality
 ('8'-'2' (38h, 32h):82: Cooling fan-3 abnormality)
 '9'-'1' (39h, 31h):91: LED Backlight abnormality
 'A'-'0' (41h, 30h):A0: Temperature abnormality - shutdown
 'A'-'1' (41h, 31h):A1: Temperature abnormality - half brightness
 'A'-'2' (41h, 32h):A2: SENSOR reached at the temperature that the user had specified.
 'B'-'0' (42h, 30h):B0: No signal
 'D'-'0' (44h, 30h):D0: PROOF OF PLAY buffer reduction

'E'-'0'(45h, 30h):E0: System error

ETX (03h): End of Message

Check code

BCC: Block Check Code

Refer to the section 4.3 "Check code" for a BCC calculation.

Delimiter

CR (0Dh): End of packet

11. Serial No. & Model Name Read

11.1 Serial No. Read

This command is used in order to read a serial number.

- 1) The controller requests the monitor to read a serial number.

Header	Message	Check code	Delimiter
SOH-'0'-Monitor ID-'0'-'A'-'0'-'6'	STX-'C'-'2'-'1'-'6'-ETX	BCC	CR

Header

SOH (01h): Start of Header
 '0' (30h): Reserved
 Monitor ID: Specify the Monitor ID which you want to get serial number.
 Ex.) If Monitor ID is '1', specify 'A'.
 '0' (30h): Message sender is the controller.
 'A' (41h): Message type is "Command".
 '0'-'6'(30h, 36h): Message length

Message

STX (02h): Start of Message
 'C'-'2'-'1'-'6' (43h, 32h, 31h, 36h): Serial No. command
 ETX (03h): End of Message

Check code

BCC: Block Check Code
 Refer to the section 4.3 "Check code" for a BCC calculation.

Delimiter

CR (0Dh): End of packet

- 2) The monitor replies the serial No. data to the controller.

Header	Message	Check code	Delimiter
SOH-'0'-'0'-Monitor ID-'B'-N-N	STX-'C'-'3'-'1'-'6'-Data(0)-Data(1)---Data(n)-ETX	BCC	CR

Header

SOH (01h): Start of Header
 '0' (30h): Reserved
 '0' (30h): Message receiver is the controller.
 Monitor ID: Indicate a replying Monitor ID.
 Ex.) When this byte is set to 'A', the replying Monitor ID is '1'.
 'B' (42h): Message type is "Command reply".
 N-N: Message length
 Note.) The maximum data length that can be returned from the monitor at a time is 32bytes.
 Ex.) The byte data 20h is encoded as ASCII characters '2' and '0' (32h and 30h).

Message

STX (02h): Start of Message
 'C'-'3'-'1'-'6' (41h, 33h, 31h, 36h): Serial No. reply command
 Data(0)-Data(1)----Data(n):Serial Number
 ➤ The byte data 20h is encoded as ASCII characters '2' and '0' (32h and 30h).
 Ex.) For example when receiving Serial Number data 33h 31h 33h 32h 33h 33h 34h
 Step1: Serial Number data is encoded as character string.
 Example:
 33h 31h 33h 32h 33h 33h 34h -> '3','1','3','2','3','3','3','4'
 Step2: Decode pairs of ASCII characters to hexadecimal values.
 Example:
 '3','1','3','2','3','3','3','4' -> 31h 32h 33h 34h
 Step3: Byte data represents the ASCII string data.
 Example:
 31h 32h 33h 34h -> "1234"
 Result: Serial Number is "1234".
 Note: No null termination character is sent.

ETX (03h): End of Message

Check code

BCC: Block Check Code

Refer to the section 4.3 "Check code" for a BCC calculation.

Delimiter

CR (0Dh): End of packet

11.2 Model Name Read

This command is used in order to read the Model Name.

1) The controller requests the monitor to read Model Name.

Header	Message	Check code	Delimiter
SOH-'0'-Monitor ID-'0'-'A'-'0'-'6'	STX-'C'-'2'-'1'-'7'-ETX	BCC	CR

Header

SOH (01h): Start of Header
 '0' (30h): Reserved
 Monitor ID: Specify the Monitor ID which you want to get Model Name.
 Ex.) If Monitor ID is '1', specify 'A'.
 '0' (30h): Message sender is the controller.
 'A' (41h): Message type is "Command".
 '0'-'6'(30h, 36h): Message length

Message

STX (02h): Start of Message
 'C'-'2'-'1'-'7' (43h, 32h, 31h, 37h): Model Name command
 ETX (03h): End of Message

Check code

BCC: Block Check Code
 Refer to the section 4.3 "Check code" for a BCC calculation.

Delimiter

CR (0Dh): End of packet

2) The monitor replies the model name data to the controller.

Header	Message	Check code	Delimiter
SOH-'0'-'0'-Monitor ID-'B'-N-N	STX-'C'-'3'-'1'-'7'-Data(0) -Data(1)----Data(n)-ETX	BCC	CR

Header

SOH (01h): Start of Header
 '0' (30h): Reserved
 '0' (30h): Message receiver is the controller.
 Monitor ID: Indicate a replying Monitor ID.
 Ex.) When this byte is set to 'A', the replying Monitor ID is '1'.
 'B' (42h): Message type is "Command reply".
 N-N: Message length

Note.) The maximum data length that can be returned from the monitor at a time is 32bytes.

Ex.) The byte data 20h is encoded as ASCII characters '2' and '0' (32h and 30h).

Message

STX (02h): Start of Message
 'C'-'3'-'1'-'7' (43h, 33h, 31h, 37h): Model Name reply Command
 Data(0) -Data(1)----Data(n):Model name

➤ The byte data 20h is encoded as ASCII characters '2' and '0' (32h and 30h).
 Ex.) For example when receiving Model Name data 35h 30h 33h 34h 33h 30h 33h 33h
 Step1: Model Name data is encoded character string.

Example:

35h 30h 33h 34h 33h 30h 33h 33h -> '5','0','3','4','3','0','3','3'

Step2: Decode pairs of ASCII characters to hexadecimal values.

Example:

'5','0','3','4','3','0','3','3' -> 50h 34h 30h 33h

Step3: Byte data represents the ASCII string data.

Example:

50h 34h 30h 33h -> "P403"

Result: Model Name is "P403".

Note: No null termination character is sent.

ETX (03h): End of Message

Check code

BCC: Block Check Code

Refer to the section 4.3 "Check code" for a BCC calculation.

Delimiter

CR (0Dh): End of packet

12. Security Lock

12.1 Security Lock Control

This command sets the condition of security lock function to "LOCK" or "UNLOCK".

If security pass codes 1st to 4th are matched with monitor resisted pass codes, then this command is executed, and reply no error status and a new condition.

If codes aren't matched with them then setting isn't changed, and reply error status and a current condition.

If the monitor receives this command while waiting for Pass codes inputs, then it only checks Pass cords (and releases image muting if Pass codes are OK) and doesn't apply "EN" parameter.

1) The controller requests the monitor to set the condition of security lock.

Header	Message	Check code	Delimiter
SOH-'0'-MonitorID-'0'-'A'-'1'-'0'	STX-'C'-'2'-'1'-'D'-EN-P1-P2-P3-P4-ETX	BCC	CR

Header

SOH (01h): Start of Header

'0' (30h): Reserved

Monitor ID: Specify the Monitor ID of which you want to change a setting.
Ex.) If Monitor ID is '1', specify 'A'.

'0' (30h): Message sender is the controller.

'A' (41h): Message type is "Command".

'1'-'0' (31h, 30h): Message length

Message

STX (02h): Start of Message

'C'-'2'-'1'-'D' (43h, 32h, 31h, 44h): Security Lock Control command

EN-P1-P2-P3-P4: Lock condition control data

EN: Enable /Disable

'0'-'0' (30h, 30h): Disable

'0'-'1' (30h, 31h): Enable

P1: Security Pass code 1st

'0'-'0' (30h, 30h): "0"

|

'0'-'9' (30h, 39h): "9"

P2: Security Pass code 2nd

'0'-'0' (30h, 30h): "0"

|

'0'-'9' (30h, 39h): "9"

P3: Security Pass code 3rd

'0'-'0' (30h, 30h): "0"

|

'0'-'9' (30h, 39h): "9"

P4: Security Pass code 4th

'0'-'0' (30h, 30h): "0"

|

'0'-'9' (30h, 39h): "9"

ETX (03h): End of Message

Check code

BCC: Block Check Code

Refer to the section 4.3 "Check code" for a BCC calculation.

Delimiter

CR (0Dh): End of packet

2) The monitor replies the result to the controller.

Header	Message	Check code	Delimiter
SOH-'0'-'0'-Monitor ID- 'B'-'0'-'A'	STX-'C'-'3'-'1'-'D'- ST-EN-ETX	BCC	CR

Header

SOH (01h): Start of Header
 '0' (30h): Reserved
 '0' (30h): Message receiver is the controller.
 Monitor ID: Indicate a replying Monitor ID.
 Ex.) When this byte is set to 'A', the replying Monitor ID is '1'.
 'B' (42h): Message type is "Command reply".
 '0'-'A'(30h, 41h): Message length

Message

STX (02h): Start of Message
 'C'-'3'-'1'-'D' (43h, 33h, 31h, 44h): Security Lock Control reply command
 ST-EN: Lock condition result data
 ST: Status
 '0'-'0'(30h, 30h): No error
 '0'-'1'(30h, 31h): Error

 EN: Enable /Disable (Current condition)
 '0'-'0'(30h, 30h): Disable
 '0'-'1'(30h, 31h): START-UP LOCK (Enable)
 '0'-'2'(30h, 32h): CONTROL LOCK
 '0'-'3'(30h, 33h): BOTH LOCK

ETX (03h): End of Message

Check code

BCC: Block Check Code
 Refer to the section 4.3 "Check code" for a BCC calculation.

Delimiter

CR (0Dh): End of packet

13. Direct TV Chanel Read & Write

When DTV unit (Option unit) is installed, channel settings is read and write directly.

13.1 Direct TV Chanel Read & Reply

- 1) The controller requests the monitor to read channel information.

Header	Message	Check code	Delimiter
SOH-'0'-Monitor ID-'0'-'A'-'0'-'6'	STX-'C'-'2'-'2'-'C'-ETX	BCC	CR

Header

SOH (01h): Start of Header
 '0' (30h): Reserved
 Monitor ID: Specify the Monitor ID which you want to get Model Name.
 Ex.) If Monitor ID is '1', specify 'A'.
 '0' (30h): Message sender is the controller.
 'A' (41h): Message type is "Command".
 '0'-'6'(30h, 36h): Message length

Message

STX (02h): Start of Message
 'C'-'2'-'2'-'C' (43h, 32h, 32h, 43h): Direct TV Channel Read command
 ETX (03h): End of Message

Check code

BCC: Block Check Code
 Refer to the section 4.3 "Check code" for a BCC calculation.

Delimiter

CR (0Dh): End of packet

- 2) The monitor replies the result to the controller.

Header	Message	Check code	Delimiter
SOH-'0'-'0'-Monitor ID-'B'-'1'-'2'	STX-'C'-'3'-'2'-'C'-MajorCH-MinorCH-ETX	BCC	CR

Header

SOH (01h): Start of Header
 '0' (30h): Reserved
 '0' (30h): Message receiver is the controller.
 Monitor ID: Indicate a replying Monitor ID.
 Ex.) When this byte is set to 'A', the replying Monitor ID is '1'.
 'B' (42h): Message type is "Command reply".
 '1'-'2'(31h, 32h): Message length = 18bytes

Message

STX (02h): Start of Message
 'C'-'3'-'2'-'C' (43h, 33h, 32h, 43h): Direct TV Channel read reply command
 MajorCH: Major Channel (0000000h - FFFFFFFh),
 '0'-'0'-'0'-'0'-'0'-'0'-'0'-'0' - 'F'-'F'-'F'-'F'-'F'-'F'-'F'-'F'
 MinorCH: Minor Channel (0000h - FFFFh),
 '0'-'0'-'0'-'0' - 'F'-'F'-'F'-'F'
 ETX (03h): End of Message

Check code

BCC: Block Check Code
 Refer to the section 4.3 "Check code" for a BCC calculation.

Delimiter

CR (0Dh): End of packet

13.2 Direct TV Chanel Write & Reply

1) The controller requests the monitor to write channel information.

Header	Message	Check code	Delimiter
SOH-'0'-Monitor ID-'0'-'A'-'1'-'2'	STX-'C'-'2'-'2'-'D'-MajorCH-MinorCH-ETX	BCC	CR

Header

SOH (01h): Start of Header
 '0' (30h): Reserved
 Monitor ID: Specify the Monitor ID which you want to get Model Name.
 Ex.) If Monitor ID is '1', specify 'A'.
 '0' (30h): Message sender is the controller.
 'A' (41h): Message type is "Command".
 '1'-'2'(31h, 32h): Message length = 18bytes

Message

STX (02h): Start of Message
 'C'-'2'-'2'-'D' (43h, 32h, 32h, 44h): Direct TV Channel write command
 MajorCH: Major Channel (00000000h - FFFFFFFFh),
 '0'-'0'-'0'-'0'-'0'-'0'-'0'-'0' - 'F'-'F'-'F'-'F'-'F'-'F'-'F'-'F'
 MinorCH: Minor Channel (0000h - FFFFh),
 '0'-'0'-'0'-'0' - 'F'-'F'-'F'-'F'
 ETX (03h): End of Message

Check code

BCC: Block Check Code
 Refer to the section 4.3 "Check code" for a BCC calculation.

Delimiter

CR (0Dh): End of packet

2) The monitor replies the result to the controller.

Header	Message	Check code	Delimiter
SOH-'0'-'0'-Monitor ID-'B'-'1'-'2'	STX-'C'-'3'-'2'-'D'-MajorCH-MinorCH-ETX	BCC	CR

Header

SOH (01h): Start of Header
 '0' (30h): Reserved
 '0' (30h): Message receiver is the controller.
 Monitor ID: Indicate a replying Monitor ID.
 Ex.) When this byte is set to 'A', the replying Monitor ID is '1'.
 'B' (42h): Message type is "Command reply".
 '1'-'2'(31h, 32h): Message length = 18bytes

Message

STX (02h): Start of Message
 'C'-'3'-'2'-'D' (43h, 33h, 32h, 43h): Direct TV Channel write reply command
 MajorCH: Major Channel (00000000h - FFFFFFFFh),
 '0'-'0'-'0'-'0'-'0'-'0'-'0'-'0' - 'F'-'F'-'F'-'F'-'F'-'F'-'F'-'F'
 MinorCH: Minor Channel (0000h - FFFFh),
 '0'-'0'-'0'-'0' - 'F'-'F'-'F'-'F'
 ETX (03h): End of Message

Check code

BCC: Block Check Code
 Refer to the section 4.3 "Check code" for a BCC calculation.

Delimiter

CR (0Dh): End of packet

14. Daylight Saving read & write

14.1 Daylight Saving Read

This command is used in order to read the setting of Daylight Saving.

- 1) The controller requests the monitor to reply a Daylight Saving setting.

Header	Message	Check code	Delimiter
SOH-'0'-Monitor ID-'0'-'A'-'0'-'8'	STX-'C'-'A'-'0'-'1'-'0'-'0'-ETX	BCC	CR

Header

SOH (01h): Start of Header
 '0' (30h): Reserved
 Monitor ID: Specify the Monitor ID of which you want to change a setting.
 Ex.) If Monitor ID is '1', specify 'A'.
 '0' (30h): Message sender is the controller.
 'A' (41h): Message type is "Command".
 '0'-'8'(30h, 38h): Message length (8bytes)

Message

STX (02h): Start of Message
 'C'-'A'-'0'-'1' (43h, 41h, 30h, 31h): Daylight Saving Command
 '0'-'0' (30h, 30h): Read
 ETX (03h): End of Message

Check code

BCC: Block Check Code
 Refer to the section 4.3 "Check code" for a BCC calculation.

Delimiter

CR (0Dh): End of packet

- 2) The monitor replies Date & Time to the controller.

Header	Message	Check code	Delimiter
SOH-'0'-'0'-Monitor ID-'B'-'2'-'0'	STX-'C'-'B'-'0'-'1'-'0'-'0'-ST-BM-BD1-BD-BT1-BT2-EM-ED1-ED2-ET1-ET2-TD-ETX	BCC	CR

Header

SOH (01h): Start of Header
 '0' (30h): Reserved
 '0' (30h): Message receiver is the controller.
 Monitor ID: Indicate a replying Monitor ID.
 Ex.) When this byte is set to 'A', replying monitor's ID is '1'.
 'B' (42h): Message type is "Command reply".
 '2'-'0'(32h, 30h): Message length (32bytes)

Message

STX (02h): Start of Message
 'C'-'B'-'0'-'1' (43h, 42h, 30h, 31h): Daylight Saving Setting reply command
 '0'-'0' (30h, 30h): Read
 ST: Error Status
 No Error : 00h (30h, 30h)
 Error : 01h (30h, 31h)
 BM: BEGIN MONTH
 JANUARY - DECEMBER: 01h (30h, 31h) - 12h (31h, 32h)
 BD1: BEGIN DAY1
 FIRST : 01h (30h, 31h)
 SECOND : 02h (30h, 32h)
 THIRD : 03h (30h, 33h)
 FOUR : 04h (30h, 34h)

LAST : 05h (30h, 35h)
BD2: BEGIN DAY2 (Day of the week)
SUNDAY : 01h (30h, 31h)
MONDAY : 02h (30h, 32h)
TUESDAY : 03h (30h, 33h)
WEDNESDAY : 04h (30h, 34h)
THURSDAY : 05h (30h, 35h)
FRIDAY : 06h (30h, 36h)
SATURDAY : 07h (30h, 37h)
BT1: BEGIN TIME1 (Hour)
00h (30h, 30h) - 23 (32h, 33h)
BT2: BEGIN TIME2 (Minute)
00h (30h, 30h) - 59 (35h, 39h)
EM: END MONTH
JANUARY - DECEMBER: 01h (30h, 31h) - 12h (31h, 32h)
ED1: END DAY1
FIRST : 01h (30h, 31h)
SECOND : 02h (30h, 32h)
THIRD : 03h (30h, 33h)
FOUR : 04h (30h, 34h)
LAST : 05h (30h, 35h)
ED2: END DAY2 (Day of the week)
SUNDAY : 01h (30h, 31h)
MONDAY : 02h (30h, 32h)
TUESDAY : 03h (30h, 33h)
WEDNESDAY : 04h (30h, 34h)
THURSDAY : 05h (30h, 35h)
FRIDAY : 06h (30h, 36h)
SATURDAY : 07h (30h, 37h)
ET1: END TIME1 (Hour)
00h (30h, 30h) - 23 (32h, 33h)
ET2: END TIME2 (Minute)
00h (30h, 30h) - 59 (35h, 39h)
TD: TIME DIFFERENCE
+01:00 : 00h (30h, 30h)
+00:30 : 01h (30h, 31h)
-00:30 : 02h (30h, 32h)
-01:00 : 03h (30h, 33h)
ETX (03h): End of Message

Check code

BCC: Block Check Code
Refer to the section 4.3 "Check code" for a BCC calculation.

Delimiter

CR (0Dh): End of packet

14.2 Daylight Saving Write

This command is used in order to write the setting of the Daylight Saving.

- 1) The controller requests the monitor to write Daylight Saving.

Header	Message	Check code	Delimiter
SOH-'0'-Monitor ID-'0'-'A'-'1'-'E'	STX-'C'-'A'-'0'-'1'-'0'-'1'-BM-BD1-BD2-BT1-BT2-EM-ED1-ED2-ET1-ET2-TD-ETX	BCC	CR

Header

SOH (01h): Start of Header
 '0' (30h): Reserved
 Monitor ID: Specify the Monitor ID of which you want to change a setting.
 Ex.) If Monitor ID is '1', specify 'A'.
 '0' (30h): Message sender is the controller.
 'A' (41h): Message type is "Command".
 '1'-'E'(31h, 45h): Message length (30bytes)

Message

STX (02h): Start of Message
 'C'-'A'-'0'-'1' (43h, 41h, 30h, 31h): Daylight Saving Setting Command
 '0'-'1' (30h, 31h): Write
 BM: BEGIN MONTH
 JANUARY - DECEMBER: 01h (30h, 31h) - 12h (31h, 32h)
 BD1: BEGIN DAY1
 FIRST : 01h (30h, 31h)
 SECOND : 02h (30h, 32h)
 THIRD : 03h (30h, 33h)
 FOUR : 04h (30h, 34h)
 LAST : 05h (30h, 35h)
 BD2: BEGIN DAY2 (Day of the week)
 SUNDAY : 01h (30h, 31h)
 MONDAY : 02h (30h, 32h)
 TUESDAY : 03h (30h, 33h)
 WEDNESDAY : 04h (30h, 34h)
 THURSDAY : 05h (30h, 35h)
 FRIDAY : 06h (30h, 36h)
 SATURDAY : 07h (30h, 37h)
 BT1: BEGIN TIME1 (Hour)
 00h (30h, 30h) - 23 (32h, 33h)
 BT2: BEGIN TIME2 (Minute)
 00h (30h, 30h) - 59 (35h, 39h)
 EM: END MONTH
 JANUARY - DECEMBER: 01h (30h, 31h) - 12h (31h, 32h)
 ED1: END DAY1
 FIRST : 01h (30h, 31h)
 SECOND : 02h (30h, 32h)
 THIRD : 03h (30h, 33h)
 FOUR : 04h (30h, 34h)
 LAST : 05h (30h, 35h)
 ED2: END DAY2 (Day of the week)
 SUNDAY : 01h (30h, 31h)
 MONDAY : 02h (30h, 32h)
 TUESDAY : 03h (30h, 33h)
 WEDNESDAY : 04h (30h, 34h)
 THURSDAY : 05h (30h, 35h)
 FRIDAY : 06h (30h, 36h)
 SATURDAY : 07h (30h, 37h)
 ET1: END TIME1 (Hour)
 00h (30h, 30h) - 23 (32h, 33h)
 ET2: END TIME2 (Minute)
 00h (30h, 30h) - 59 (35h, 39h)
 TD: TIME DIFFERENCE
 +01:00 : 00h (30h, 30h)
 +00:30 : 01h (30h, 31h)

-00:30 : 02h (30h, 32h)
 -01:00 : 03h (30h, 33h)
 ETX (03h): End of Message

Check code

BCC: Block Check Code
 Refer to the section 4.3 "Check code" for a BCC calculation.

Delimiter

CR (0Dh): End of packet

2) The monitor replies a written in result.

Header	Message	Check code	Delimiter
SOH-'0'-'0'-Monitor ID-'B'-'0'-'A'	STX-'C'-'B'-'0'-'1'-'0'-'1'-ST-ETX	BCC	CR

Header

SOH (01h): Start of Header
 '0' (30h): Reserved
 '0' (30h): Message receiver is the controller.
 Monitor ID: Indicate a replying Monitor ID.
 Ex.) When this byte is set to 'A', replying monitor's ID is '1'.
 'B' (42h): Message type is "Command reply".
 '0'-'A'(30h, 41h): Message length (10bytes)

Message

STX (02h): Start of Message
 'C'-'B'-'0'-'1' (43h, 42h, 30h, 31h): Daylight Saving Setting Command
 '0'-'1' (30h, 31h): Write
 ST: Error Status
 No Error : 00h (30h, 30h)
 Error : 01h (30h, 31h)
 ETX (03h): End of Message

Check code

BCC: Block Check Code
 Refer to the section 4.3 "Check code" for a BCC calculation.

Delimiter

CR (0Dh): End of packet

15. Firmware Version

15.1 Firmware Version Read

This command is used in order to read a firmware version (FIRMWARE REVISION).

- 1) The controller requests the monitor to reply a firmware version.

Header	Message	Check code	Delimiter
SOH-'0'-Monitor ID-'0'-'A'-'0'-'8'	STX-'C'-'A'-'0'-'2'-TY-ETX	BCC	CR

Header

SOH (01h): Start of Header
'0' (30h): Reserved
Monitor ID: Specify the Monitor ID of which you want to change a setting.
Ex.) If Monitor ID is '1', specify 'A'.
'0' (30h): Message sender is the controller.
'A' (41h): Message type is "Command".
'0'-'8'(30h, 38h): Message length (8bytes)

Message

STX (02h): Start of Message
'C'-'A'-'0'-'2' (43h, 41h, 30h, 32h): Firmware Version Command
TY: Firmware Type
Firmware: 00h (30h, 30h)
ETX (03h): End of Message

Check code

BCC: Block Check Code
Refer to the section 4.3 "Check code" for a BCC calculation.

Delimiter

CR (0Dh): End of packet

- 2) The monitor replies a firmware version to the controller.

Header	Message	Check code	Delimiter
SOH-'0'-Monitor ID-'0'-'B'-'1'-'1'	STX-'C'-'B'-'0'-'2'-ST-TY-MV-PP-BV1-BV2-BV3-BR1-BR2-ETX	BCC	CR

Header

SOH (01h): Start of Header
'0' (30h): Reserved
'0' (30h): Message receiver is the controller.
Monitor ID: Indicate a replying Monitor ID.
Ex.) When this byte is set to 'A', replying monitor's ID is '1'.
'B' (42h): Message type is "Command reply".
'1'-'1'(31h, 31h): Message length (17bytes)

Message

STX (02h): Start of Message
'C'-'B'-'0'-'2' (43h, 42h, 30h, 32h): Firmware Version Read reply
ST: Error Status
No Error : 00h (30h, 30h)
Error : 01h (30h, 31h)
TY: Firmware Type
Firmware : 00h (30h, 30h)
MV: Major Version:
00h (30h, 30h) - 09h (30h, 39h)
PP: Period:
2Eh (32h, 45h) (fixed)
BV1: Minor (Basic) Version1:

00h (30h, 30h) - 09h (30h, 39h)
BV2: Minor (Basic) Version2:
00h (30h, 30h) - 09h (30h, 39h)
BV3: Minor (Basic) Version3:
00h (30h, 30h) - 09h (30h, 39h)
BR1: Branch Version1:
A:41h (34h, 31h) - Z:5Ah (35h, 41h)
BR2: Branch Version2:
A:41h (34h, 31h) - Z:5Ah (35h, 41h)

Check code

BCC: Block Check Code

Refer to the section 4.3 "Check code" for a BCC calculation.

Delimiter

CR (0Dh): End of packet

16. Auto ID

16.1 Auto ID Execute

This command is used in order to execute Auto ID function.

- 1) The controller requests the monitor to execute Auto ID function.

Header	Message	Check code	Delimiter
SOH-'0'-Monitor ID-'0'-'A'-'0'-'8'	STX-'C'-'A'-'0'-'A'-'0'-'1'-ETX	BCC	CR

Header

SOH (01h): Start of Header
'0' (30h): Reserved
Monitor ID: Specify the Monitor ID of which you want to change a setting.
Ex.) If Monitor ID is '1', specify 'A'.
'0' (30h): Message sender is the controller.
'A' (41h): Message type is "Command".
'0'-'8'(30h, 38h): Message length (8byte)

Message

STX (02h): Start of Message
'C'-'A'-'0'-'A' (43h, 41h, 30h, 41h, 30h, 31h): Auto ID Command
'0'-'1' (30h, 30h): Execute
ETX (03h): End of Message

Check code

BCC: Block Check Code
Refer to the section 4.3 "Check code" for a BCC calculation.

Delimiter

CR (0Dh): End of packet

- 2) The monitor replies receipt result.

Header	Message	Check code	Delimiter
SOH-'0'-'0'-Monitor ID-'B'-'0'-'A'	STX-'C'-'B'-'0'-'A'-'0'-'1'-ST-ETX	BCC	CR

Header

SOH (01h): Start of Header
'0' (30h): Reserved
'0' (30h): Message receiver is the controller.
Monitor ID: Indicate a replying Monitor ID.
Ex.) When this byte is set to 'A', replying monitor's ID is '1'.
'B' (42h): Message type is "Command reply".
'0'-'A'(30h,41h): Message length (10byte)

Message

STX (02h): Start of Message
'C'-'B'-'0'-'A' (43h, 42h, 30h, 41h, 30h, 31h): Auto ID Reply Command
'0'-'1' (30h, 30h): Execute
ST: Error Status
No Error : 00h (30h, 30h)
Error : 01h (30h, 31h)
ETX (03h): End of Message

Check code

BCC: Block Check Code
Refer to the section 4.3 "Check code" for a BCC calculation.

Delimiter

CR (0Dh): End of packet

16.2 Auto ID Complete

This command is used in order to notify complete status of Auto ID.

- 1) The monitor sends the controller to complete status of Auto ID.

Header	Message	Check code	Delimiter
SOH-'0'-Monitor ID-'0'-'A'-'0'-'C'	STX-'C'-'A'-'0'-'A'-'0'-'2'-ST-MON-ETX	BCC	CR

Header

SOH (01h): Start of Header
 '0' (30h): Reserved
 Monitor ID: Specify the Monitor ID of which you want to change a setting.
 Ex.) If Monitor ID is '1', specify 'A'.
 '0' (30h): Message sender is the controller.
 'A' (41h): Message type is "Command".
 '0'-'C'(30h,43h): Message length (12byte)

Message

STX (02h): Start of Message
 'C'-'A'-'0'-'A'-'0'-'2' (43h, 41h, 30h, 41h, 30h, 32h): Auto ID
 '0'-'2' (30h,32h): Complete
 ST: Error Status
 No Error: 00h (30h, 30h)
 Error : 01h (30h, 31h)
 MON: DETECTED MONITORS
 01h (30h, 31h) - 64h (36h, 34h)
 ETX (03h): End of Message

Check code

BCC: Block Check Code
 Refer to the section 4.3 "Check code" for a BCC calculation.

Delimiter

CR (0Dh): End of packet

- 2) The controller replies to the monitor.

Header	Message	Check code	Delimiter
SOH-'0'-'0'-Monitor ID-'B'-'0'-'A'	STX-'C'-'B'-'0'-'A'-'0'-'2'-ST-ETX	BCC	CR

Header

SOH (01h): Start of Header
 '0' (30h): Reserved
 '0' (30h): Message receiver is the controller.
 Monitor ID: Indicate a replying Monitor ID.
 Ex.) When this byte is set to 'A', replying monitor's ID is '1'.
 'B' (42h): Message type is "Command reply".
 '0'-'A'(30h,41h): Message length (10byte)

Message

STX (02h): Start of Message
 'C'-'B'-'0'-'A' (43h, 42h, 30h, 41h): Auto ID Reply Command
 '0'-'2' (30h,32h): Complete
 ST : Error Status
 No Error: 00h (30h, 30h) *Fixed
 ETX (03h): End of Message

Check code

BCC: Block Check Code
 Refer to the section 4.3 "Check code" for a BCC calculation.

Delimiter

CR (0Dh): End of packet

16.3 Auto ID Reset

This command is used in order to reset Auto ID.

- 1) The controller requests the monitor to reset Auto ID.

Header	Message	Check code	Delimiter
SOH-'0'-Monitor ID-'0'-'A'-'0'-'8'	STX-'C'-'A'-'0'-'A'-'0'-'3'-ETX	BCC	CR

Header

SOH (01h): Start of Header
 '0' (30h): Reserved
 Monitor ID: Specify the Monitor ID of which you want to change a setting.
 Ex.) If Monitor ID is '1', specify 'A'.
 '0' (30h): Message sender is the controller.
 'A' (41h): Message type is "Command".
 '0'-'8'(30h, 38h): Message length (8byte)

Message

STX (02h): Start of Message
 'C'-'A'-'0'-'A' (43h, 41h, 30h, 41h): Auto ID Command
 '0'-'3' (30h, 33h): Reset
 ETX (03h): End of Message

Check code

BCC: Block Check Code
 Refer to the section 4.3 "Check code" for a BCC calculation.

Delimiter

CR (0Dh): End of packet

- 2) The monitor replies to the controller.

Header	Message	Check code	Delimiter
SOH-'0'-'0'-Monitor ID-'B'-'0'-'A'	STX-'C'-'B'-'0'-'A'-'0'-'3'-ST-ETX	BCC	CR

Header

SOH (01h): Start of Header
 '0' (30h): Reserved
 '0' (30h): Message receiver is the controller.
 Monitor ID: Indicate a replying Monitor ID.
 Ex.) When this byte is set to 'A', replying monitor's ID is '1'.
 'B' (42h): Message type is "Command reply".
 '0'-'A'(30h,41h): Message length (10byte)

Message

STX (02h): Start of Message
 'C'-'B'-'0'-'A' (43h, 42h, 30h, 41h): Auto ID Reply
 '0'-'3' (30h, 33h): Reset
 ST: Error Status
 No Error : 00h (30h, 30h)
 Error : 01h (30h, 31h)
 ETX (03h): End of Message

Check code

BCC: Block Check Code
 Refer to the section 4.3 "Check code" for a BCC calculation.

Delimiter

CR (0Dh): End of packet

17. Input Name

17.1 Input Name Read

This command is used in order to read the setting of Input Name.

- 1) The controller requests the monitor to reply Input Name setting.

Header	Message	Check code	Delimiter
SOH-'0'-Monitor ID-'0'-'A'-'0'-'8'	STX-'C'-'A'-'0'-'4'-'0'-'0'-ETX	BCC	CR

Header

SOH (01h): Start of Header
'0' (30h): Reserved
Monitor ID: Specify the Monitor ID of which you want to change a setting.
Ex.) If Monitor ID is '1', specify 'A'.
'0' (30h): Message sender is the controller.
'A' (41h): Message type is "Command".
'0'-'8'(30h, 38h): Message length (8bytes)

Message

STX (02h): Start of Message
'C'-'A'-'0'-'4' (43h, 41h, 30h, 34h): Input Name Command
'0'-'0' (30h, 30h): Read
ETX (03h): End of Message

Check code

BCC: Block Check Code
Refer to the section 4.3 "Check code" for a BCC calculation.

Delimiter

CR (0Dh): End of packet

- 2) The monitor replies Input Name to the controller.

Header	Message	Check code	Delimiter
SOH-'0'-'0'-Monitor ID-'B'-LN(H)-LN(L)	STX-'C'-'B'-'0'-'4'-'0'-'0'-Data(0)-Data(1)-Data(2)- --- -Data(n)-ETX	BCC	CR

Header

SOH (01h): Start of Header
'0' (30h): Reserved
'0' (30h): Message receiver is the controller.
Monitor ID: Indicate a replying Monitor ID.
Ex.) When this byte is set to 'A', replying monitor's ID is '1'.
'B' (42h): Message type is "Command reply".
LN(H)-LN(L): Message length (byte length), from STX to ETX
Ex.) The byte data 20h is encoded as ASCII characters '2' and '0' (32h and 30h).

Message

STX (02h): Start of Message
'C'-'B'-'0'-'4' (43h, 42h, 30h, 34h): Input Name command reply
'0'-'0' (30h, 30h): Read
Data(n) : Input name *n = Max 14
➤ The byte data 20h is encoded as ASCII characters '2' and '0' (32h and 30h).
Ex.) For example when receiving Data(n) of 35h 36h 34h 37h 34h 31h
Step1: Input Name data is encoded as character code.
Example:
35h 36h 34h 37h 34h 31h -> '5'-'6'-'4'-'7'-'4'-'1'
Step2: Decode pairs of ASCII characters to hexadecimal values.
Example:
'5'-'6'-'4'-'7'-'4'-'1' -> 56h 47h 41h

Step3: Byte data represents the ASCII string data.

Example:

56h 47h 41h -> "VGA"

Result: Input Name is "VGA".

Note: No null termination character is sent.

ETX (03h): End of Message

Check code

BCC: Block Check Code

Refer to the section 4.3 "Check code" for a BCC calculation.

Delimiter

CR (0Dh): End of packet

17.2 Input Name Write

This command is used in order to write the setting of Input Name.

1) The controller requests the monitor to write Input Name.

Header	Message	Check code	Delimiter
SOH-'0'-Monitor ID-'0'-'A'- LN(H)-LN(L)	STX-'C'-'A'-'0'-'4'-'0'-'1'-Data(0)-Data(1)-Data(2)- --- -Data(n)-ETX	BCC	CR

Header

SOH (01h): Start of Header
 '0' (30h): Reserved
 Monitor ID: Specify the Monitor ID of which you want to change a setting.
 Ex.) If Monitor ID is '1', specify 'A'.
 '0' (30h): Message sender is the controller.
 'A' (41h): Message type is "Command".
 LN(H)-LN(L): Message length (byte length), from STX to ETX
 Ex.) The byte data 20h is encoded as ASCII characters '2' and '0' (32h and 30h).

Message

STX (02h): Start of Message
 'C'-'A'-'0'-'4' (43h, 41h, 30h, 34h): Input name Command
 '0'-'1' (30h, 31h): Write
 Data(n) : Input name *n = Max 14
 > The byte data 20h is encoded as ASCII characters '2' and '0' (32h and 30h).
 Ex.) In the case of Input Name "VGA"
 Step1: Input Name data is handled as character code.
 Example:
 "VGA" -> 56h 47h 41h (ASCII)
 Step2: The hexadecimal value of each original character is encoded as two ASCII characters representing the value.
 Example:
 56h 47h 41h -> '5'-'6'-'4'-'7'-'4'-'1'
 Result: The following data is assigned to Data(n).
 35h 36h 34h 37h 34h 31h
 ETX (03h): End of Message

Check code

BCC: Block Check Code
 Refer to the section 4.3 "Check code" for a BCC calculation.

Delimiter

CR (0Dh): End of packet

2) The monitor replies a written in result.

Header	Message	Check code	Delimiter
SOH-'0'-'0'-Monitor ID-'B'-'0'-'A'	STX-'C'-'B'-'0'-'0'-'0'-'1'-ST-ETX	BCC	CR

Header

SOH (01h): Start of Header
 '0' (30h): Reserved
 '0' (30h): Message receiver is the controller.
 Monitor ID: Indicate a replying Monitor ID.
 Ex.) When this byte is set to 'A', replying monitor's ID is '1'.
 'B' (42h): Message type is "Command reply".
 '0'-'A'(30h, 41h): Message length (10bytes)

Message

STX (02h): Start of Message
 'C'-'B'-'0'-'4' (43h, 42h, 30h, 34h): Input name Command
 '0'-'1' (30h, 31h): Write

ST: Status
00h (30h, 30h): No Error
01h (30h, 31h): Error
ETX (03h): End of Message

Check code

BCC: Block Check Code
Refer to the section 4.3 "Check code" for a BCC calculation.

Delimiter

CR (0Dh): End of packet

17.3 Input Name Reset

This command is used in order to reset the Input Name.

- 1) The controller requests the monitor to reset Input Name.

Header	Message	Check code	Delimiter
SOH-'0'-Monitor ID-'0'-'A'-'0'-'8'	STX-'C'-'A'-'0'-'4'-'0'-'2'-ETX	BCC	CR

Header

SOH (01h): Start of Header
'0' (30h): Reserved
Monitor ID: Specify the Monitor ID of which you want to change a setting.
Ex.) If Monitor ID is '1', specify 'A'.
'0' (30h): Message sender is the controller.
'A' (41h): Message type is "Command".
'0'-'8'(30h, 38h): Message length (8bytes)

Message

STX (02h): Start of Message
'C'-'A'-'0'-'4' (43h, 41h, 30h, 34h): Input Name Command
'0'-'2' (30h, 32h): Reset
ETX (03h): End of Message

Check code

BCC: Block Check Code
Refer to the section 4.3 "Check code" for a BCC calculation.

Delimiter

CR (0Dh): End of packet

- 2) The monitor replies result.

Header	Message	Check code	Delimiter
SOH-'0'-'0'-Monitor ID-'B'-'0'-'A'	STX-'C'-'B'-'0'-'0'-'0'-'2'-ST-ETX	BCC	CR

Header

SOH (01h): Start of Header
'0' (30h): Reserved
'0' (30h): Message receiver is the controller.
Monitor ID: Indicate a replying Monitor ID.
Ex.) When this byte is set to 'A', replying monitor's ID is '1'.
'B' (42h): Message type is "Command reply".
'0'-'A'(30h, 41h): Message length (10bytes)

Message

STX (02h): Start of Message
'C'-'B'-'0'-'4' (43h, 42h, 30h, 34h): Input name Command
'0'-'2' (30h, 32h): Reset
ST: Status
00h (30h, 30h): No Error
01h (30h, 31h): Error
ETX (03h): End of Message

Check code

BCC: Block Check Code
Refer to the section 4.3 "Check code" for a BCC calculation.

Delimiter

CR (0Dh): End of packet

18. Auto Tile Matrix

18.1 Auto Tile Matrix Execute

This command is used in order to activate the Auto Tile Matrix Setup.

- 1) The controller requests the monitor to execute Auto Tile Matrix

Header	Message	Check code	Delimiter
SOH-'0'-Monitor ID-'0'-'A'-'1'-'2'	STX-'C'-'A'-'0'-'3'-'0'-'1'-HM-VM-PID-SEL-TMEM-ETX	BCC	CR

Header

SOH (01h): Start of Header
'0' (30h): Reserved
Monitor ID: Specify the Monitor ID of which you want to change a setting.
Ex.) If Monitor ID is '1', specify 'A'.
'0' (30h): Message sender is the controller.
'A' (41h): Message type is "Command".
'1'-'2'(31h, 32h): Message length (18bytes)

Message

STX (02h): Start of Message
'C'-'A'-'0'-'3' (43h, 41h, 30h, 33h): Auto Tile Matrix Command
'0'-'1' (30h, 31h): Execution
HM: HORIZONTAL MONITORS
01h (30h, 31h) - 10h (31h, 30h)
VM: VERTICAL MONITORS
01h (30h, 31h) - 10h (31h, 30h)
PID: PATTERN ID
01h (30h, 31h) *Fixed
SEL: CURRENT INPUT SELECT
VGA(RGB) : 01h (30h, 31h)
DVI : 03h (30h, 33h)
VIDEO : 05h (30h, 35h)
VGA(YPbPr) : 0Ch (30h, 43h)
OPTION : 0Dh (30h, 44h)
DisplayPort1 : 0Fh (30h, 46h)
DisplayPort2 : 10h (31h, 30h)
HDMI1 : 11h (31h, 31h)
HDMI2 : 12h (31h, 32h)
MP : 87h (38h, 37h)
COMPUTE MODULE : 87h (38h, 37h)
TMEM: TILE MATRIX MEM
COMMON : 00h (30h, 30h)
INPUT : 01h (30h, 31h)
ETX (03h): End of Message

Check code

BCC: Block Check Code
Refer to the section 4.3 "Check code" for a BCC calculation.

Delimiter

CR (0Dh): End of packet

- 2) The monitor replies receipt result.

Header	Message	Check code	Delimiter
SOH-'0'-'0'-Monitor ID-'B'-'0'-'A'	STX-'C'-'B'-'0'-'3'-'0'-'1'-ST-ETX	BCC	CR

Header

SOH (01h): Start of Header
'0' (30h): Reserved
'0' (30h): Message receiver is the controller.

Monitor ID: Indicate a replying Monitor ID.

Ex.) When this byte is set to 'A', replying monitor's ID is '1'.
'B' (42h): Message type is "Command reply".
'0'-'A'(30h, 41h): Message length (10bytes)

Message

STX (02h): Start of Message
'C'-'B'-'0'-'3' (43h, 42h, 30h, 33h): Auto Tile Matrix Command
'0'-'1' (30h, 31h): Execution
ST: Error Status
 No Error: 00h (30h, 30h)
 Error : 01h (30h, 31h)
ETX (03h): End of Message

Check code

BCC: Block Check Code
 Refer to the section 4.3 "Check code" for a BCC calculation.

Delimiter

CR (0Dh): End of packet

18.2 Auto Tile Matrix Complete

This command is used in order to notify complete status of Auto Tile Matrix Setup.

- 1) The monitor notifies that Auto Tile Matrix completed to controller.

Header	Message	Check code	Delimiter
SOH-'0'-Monitor ID-'0'-'A'-'0'-'A'	STX-'C'-'A'-'0'-'3'-'0'-'2'-ST-ETX	BCC	CR

Header

SOH (01h): Start of Header
 '0' (30h): Reserved
 Monitor ID: Specify the Monitor ID of which you want to change a setting.
 Ex.) If Monitor ID is '1', specify 'A'.
 '0' (30h): Message sender is the controller.
 'A' (41h): Message type is "Command".
 '0'-'A'(30h, 41h): Message length (10bytes)

Message

STX (02h): Start of Message
 'C'-'A'-'0'-'3'-'0'-'2' (43h, 41h, 30h, 33h, 30h, 32h): Auto Tile Matrix Complete
 '0'-'2' (30h, 32h): Notify
 ST: Error Status
 No Error: 00h (30h, 30h)
 Error : 01h (30h, 31h)
 ETX (03h): End of Message

Check code

BCC: Block Check Code
 Refer to the section 4.3 "Check code" for a BCC calculation.

Delimiter

CR (0Dh): End of packet

- 2) The controller replies to the monitor.

Header	Message	Check code	Delimiter
SOH-'0'-'0'-Monitor ID-'B'-'0'-'A'	STX-'C'-'B'-'0'-'3'-'0'-'2'-ST-ETX	BCC	CR

Header

SOH (01h): Start of Header
 '0' (30h): Reserved
 '0' (30h): Message receiver is the controller.
 Monitor ID: Indicate a replying Monitor ID.
 Ex.) When this byte is set to 'A', replying monitor's ID is '1'.
 'B' (42h): Message type is "Command reply".
 '0'-'A'(30h, 41h): Message length (10bytes)

Message

STX (02h): Start of Message
 'C'-'B'-'0'-'3' (43h, 42h, 30h, 33h): Auto Tile Matrix Command
 '0'-'2' (30h, 32h): Notify
 ST: Error Status
 No Error: 00h (30h, 30h) *Fixed
 ETX (03h): End of Message

Check code

BCC: Block Check Code
 Refer to the section 4.3 "Check code" for a BCC calculation.

Delimiter

CR (0Dh): End of packet

18.3 Auto Tile Matrix Monitors Read

This command is used in order to read the setting of H/V Monitors.

- 1) The controller requests the monitor to reply H/V Monitors setting.

Header	Message	Check code	Delimiter
SOH-'0'-Monitor ID-'0'-'A'-'0'-'8'	STX-'C'-'A'-'0'-'3'-'0'-'4'-ETX	BCC	CR

Header

SOH (01h): Start of Header
 '0' (30h): Reserved
 Monitor ID: Specify the Monitor ID of which you want to change a setting.
 Ex.) If Monitor ID is '1', specify 'A'.
 '0' (30h): Message sender is the controller.
 'A' (41h): Message type is "Command".
 '0'-'8'(30h, 38h): Message length (8bytes)

Message

STX (02h): Start of Message
 'C'-'A'-'0'-'3' (43h, 41h, 30h, 33h): Auto Tile Matrix Command
 '0'-'4' (30h, 34h): Monitors Read
 ETX (03h): End of Message

Check code

BCC: Block Check Code
 Refer to the section 4.3 "Check code" for a BCC calculation.

Delimiter

CR (0Dh): End of packet

- 2) The monitor replies H/V Monitors to the controller.

Header	Message	Check code	Delimiter
SOH-'0'-'0'-Monitor ID-'B'-'0'-'E'	STX-'C'-'B'-'0'-'3'-'0'-'4'-ST-HM-VM-ETX	BCC	CR

Header

SOH (01h): Start of Header
 '0' (30h): Reserved
 '0' (30h): Message receiver is the controller.
 Monitor ID: Indicate a replying Monitor ID.
 Ex.) When this byte is set to 'A', replying monitor's ID is '1'.
 'B' (42h): Message type is "Command reply".
 '0'-'E'(30h, 45h): Message length (14bytes)

Message

STX (02h): Start of Message
 'C'-'B'-'0'-'3' (43h, 42h, 30h, 33h): Auto Tile Matrix reply
 '0'-'4' (30h, 34h): Monitors Read
 ST: Error Status
 No Error : 00h (30h, 30h)
 Error : 01h (30h, 31h)
 HM: H MONITORS
 00h - 0Ah (30h, 30h - 30h, 41h)
 VM: V MONITORS
 00h - 0Ah (30h, 30h - 30h, 41h)
 ETX (03h): End of Message

Check code

BCC: Block Check Code
 Refer to the section 4.3 "Check code" for a BCC calculation.

Delimiter

CR (0Dh): End of packet

18.4 Auto Tile Matrix Monitors Write

This command is used in order to write the setting of H/V Monitors.

- 1) The controller requests the monitor to write H/V Monitors.

Header	Message	Check code	Delimiter
SOH-'0'-Monitor ID-'0'-'A'-'0'-'C'	STX-'C'-'A'-'0'-'3'-'0'-'5'-HM-VM-ETX	BCC	CR

Header

SOH (01h): Start of Header
 '0' (30h): Reserved
 Monitor ID: Specify the Monitor ID of which you want to change a setting.
 Ex.) If Monitor ID is '1', specify 'A'.
 '0' (30h): Message sender is the controller.
 'A' (41h): Message type is "Command".
 '0'-'C'(30h, 43h): Message length (12bytes)

Message

STX (02h): Start of Message
 'C'-'A'-'0'-'3' (43h, 41h, 30h, 33h): Auto Tile Matrix Command
 '0'-'5' (30h, 34h): Monitors Write
 HM: H MONITORS
 00h - 0Ah (30h, 30h - 30h, 41h)
 VM: V MONITORS
 00h - 0Ah (30h, 30h - 30h, 41h)
 ETX (03h): End of Message

Check code

BCC: Block Check Code
 Refer to the section 4.3 "Check code" for a BCC calculation.

Delimiter

CR (0Dh): End of packet

- 2) The monitor replies a written in result.

Header	Message	Check code	Delimiter
SOH-'0'-'0'-Monitor ID-'B'-'0'-'A'	STX-'C'-'B'-'0'-'3'-'0'-'5'-ST-ETX	BCC	CR

Header

SOH (01h): Start of Header
 '0' (30h): Reserved
 '0' (30h): Message receiver is the controller.
 Monitor ID: Indicate a replying Monitor ID.
 Ex.) When this byte is set to 'A', replying monitor's ID is '1'.
 'B' (42h): Message type is "Command reply".
 '0'-'A'(30h, 41h): Message length (14bytes)

Message

STX (02h): Start of Message
 'C'-'B'-'0'-'3' (43h, 42h, 30h, 33h): Auto Tile Matrix reply
 '0'-'5' (30h, 34h): Monitors Write
 ST: Error Status
 No Error : 00h (30h, 30h)
 Error : 01h (30h, 31h)
 ETX (03h): End of Message

Check code

BCC: Block Check Code
 Refer to the section 4.3 "Check code" for a BCC calculation.

Delimiter

CR (0Dh): End of packet

18.5 Auto Tile Matrix Reset

This command is used in order to deactivate the Auto Tile Matrix Setup.

- 1) The controller requests the monitor to reset Auto Tile Matrix

Header	Message	Check code	Delimiter
SOH-'0'-Monitor ID-'0'-'A'-'0'-'8'	STX-'C'-'A'-'0'-'3'-'0'-'6'-ETX	BCC	CR

Header

SOH (01h): Start of Header
 '0' (30h): Reserved
 Monitor ID: Specify the Monitor ID of which you want to change a setting.
 Ex.) If Monitor ID is '1', specify 'A'.
 '0' (30h): Message sender is the controller.
 'A' (41h): Message type is "Command".
 '0'-'8'(30h, 38h): Message length (8bytes)

Message

STX (02h): Start of Message
 'C'-'A'-'0'-'3' (43h, 41h, 30h, 33h, 30h, 33h): Auto Tile Matrix
 '0'-'6' (30h, 36h): Off
 ETX (03h): End of Message

Check code

BCC: Block Check Code
 Refer to the section 4.3 "Check code" for a BCC calculation.

Delimiter

CR (0Dh): End of packet

- 2) The monitor replies receipt result.

Header	Message	Check code	Delimiter
SOH-'0'-'0'-Monitor ID-'B'-'0'-'A'	STX-'C'-'B'-'0'-'3'-'0'-'6'-ST-ETX	BCC	CR

Header

SOH (01h): Start of Header
 '0' (30h): Reserved
 '0' (30h): Message receiver is the controller.
 Monitor ID: Indicate a replying Monitor ID.
 Ex.) When this byte is set to 'A', replying monitor's ID is '1'.
 'B' (42h): Message type is "Command reply".
 '0'-'A'(30h, 41h): Message length (10bytes)

Message

STX (02h): Start of Message
 'C'-'B'-'0'-'3' (43h, 42h, 30h, 33h) : Auto Tile Matrix
 '0'-'6' (30h, 36h): Off
 ST: Error Status
 No Error : 00h (30h, 30h)
 Error : 01h (30h, 31h)
 ETX (03h): End of Message

Check code

BCC: Block Check Code
 Refer to the section 4.3 "Check code" for a BCC calculation.

Delimiter

CR (0Dh): End of packet

19. Power Save Mode

19.1 Auto Power Save Time Read

This command is used in order to read the setting of Auto Power Save Time.

- 1) The controller requests the monitor to reply Time setting.

Header	Message	Check code	Delimiter
SOH-'0'-Monitor ID-'0'-'A'-'0'-'8'	STX-'C'-'A'-'0'-'B'-'0'-'2'-ETX	BCC	CR

Header

SOH (01h): Start of Header
 '0' (30h): Reserved
 Monitor ID: Specify the Monitor ID of which you want to change a setting.
 Ex.) If Monitor ID is '1', specify 'A'.
 '0' (30h): Message sender is the controller.
 'A' (41h): Message type is "Command".
 '0'-'8'(30h,38h): Message length (8byte)

Message

STX (02h): Start of Message
 'C'-'A'-'0'-'B' (43h, 41h, 30h, 42h): Power Save Mode command
 '0'-'2' (30h, 30h): Auto Power Save Read
 ETX (03h): End of Message

Check code

BCC: Block Check Code
 Refer to the section 4.3 "Check code" for a BCC calculation.

Delimiter

CR (0Dh): End of packet

- 2) The monitor replies Time to the controller.

Header	Message	Check code	Delimiter
SOH-'0'-'0'-Monitor ID-'B'-'0'-'A'	STX-'C'-'B'-'0'-'B'-'0'-'2'-TIME-ETX	BCC	CR

Header

SOH (01h): Start of Header
 '0' (30h): Reserved
 '0' (30h): Message receiver is the controller.
 Monitor ID: Indicate a replying Monitor ID.
 Ex.) When this byte is set to 'A', replying monitor's ID is '1'.
 'B' (42h): Message type is "Command reply".
 '0'-'A'(30h,41h): Message length (10byte)

Message

STX (02h): Start of Message
 'C'-'B'-'0'-'B' (43h, 42h, 30h, 42h): Power Save Mode Reply
 '0'-'2' (30h, 32h): Auto Power Save Time Read
 TIME: AUTO POWER SAVE TIME (sec.)
 00h (30h, 30h) - 78h (37h, 38h): 1 (5dec.) - 120 (600sec.)
 ETX (03h): End of Message

Check code

BCC: Block Check Code
 Refer to the section 4.3 "Check code" for a BCC calculation.

Delimiter

CR (0Dh): End of packet

19.2 Auto Power Save Time Write

This command is used in order to write the setting of Auto Power Save Time.

1) The controller requests the monitor to write Time.

Header	Message	Check code	Delimiter
SOH-'0'-Monitor ID-'0'-'A'-'0'-'A'	STX-'C'-'A'-'0'-'B'-'0'-'3'-TIME-ETX	BCC	CR

Header

SOH (01h): Start of Header
 '0' (30h): Reserved
 Monitor ID: Specify the Monitor ID of which you want to change a setting.
 Ex.) If Monitor ID is '1', specify 'A'.
 '0' (30h): Message sender is the controller.
 'A' (41h): Message type is "Command".
 '0'-'A'(30h,41h): Message length (10byte)

Message

STX (02h): Start of Message
 'C'-'A'-'0'-'B' (43h, 41h, 30h, 42h): Power Save Mode command
 '0'-'3' (30h, 33h): Auto Power Save Time Write
 TIME: AUTO POWER SAVE TIME (sec.)
 00h (30h, 30h) - 78h (37h, 38h): 1 (5dec.) - 120 (600sec.)
 ETX (03h): End of Message

Check code

BCC: Block Check Code
 Refer to the section 4.3 "Check code" for a BCC calculation.

Delimiter

CR (0Dh): End of packet

2) The monitor replies a written in result.

Header	Message	Check code	Delimiter
SOH-'0'-'0'-Monitor ID-'B'-'0'-'8'	STX-'C'-'B'-'0'-'B'-'0'-'3'-ST-ETX	BCC	CR

Header

SOH (01h): Start of Header
 '0' (30h): Reserved
 '0' (30h): Message receiver is the controller.
 Monitor ID: Indicate a replying Monitor ID.
 Ex.) When this byte is set to 'A', replying monitor's ID is '1'.
 'B' (42h): Message type is "Command reply".
 '0'-'8'(30h,38h): Message length (8byte)

Message

STX (02h): Start of Message
 'C'-'B'-'0'-'B' (43h, 42h, 30h, 42h): Power Save Mode Reply
 '0'-'3' (30h, 33h): Auto Power Save Time Write
 ST: Error Status
 No Error : 00h (30h, 30h)
 Error : 01h (30h, 31h)
 ETX (03h): End of Message

Check code

BCC: Block Check Code
 Refer to the section 4.3 "Check code" for a BCC calculation.

Delimiter

CR (0Dh): End of packet

19.3 Auto Standby Time Read

This command is used in order to read the setting of Auto Standby Time.

- 1) The controller requests the monitor to reply Time setting.

Header	Message	Check code	Delimiter
SOH-'0'-Monitor ID-'0'-'A'-'0'-'8'	STX-'C'-'A'-'0'-'B'-'0'-'4'-ETX	BCC	CR

Header

SOH (01h): Start of Header
 '0' (30h): Reserved
 Monitor ID: Specify the Monitor ID of which you want to change a setting.
 Ex.) If Monitor ID is '1', specify 'A'.
 '0' (30h): Message sender is the controller.
 'A' (41h): Message type is "Command".
 '0'-'8' (30h,38h): Message length (8byte)

Message

STX (02h): Start of Message
 'C'-'A'-'0'-'B' (43h, 41h, 30h, 42h): Power Save Mode command
 '0'-'4' (30h, 30h): Auto Standby Time Read
 ETX (03h): End of Message

Check code

BCC: Block Check Code
 Refer to the section 4.3 "Check code" for a BCC calculation.

Delimiter

CR (0Dh): End of packet

- 2) The monitor replies Time to the controller.

Header	Message	Check code	Delimiter
SOH-'0'-'0'-Monitor ID-'B'-'0'-'A'	STX-'C'-'B'-'0'-'B'-'0'-'4'-TIME-ETX	BCC	CR

Header

SOH (01h): Start of Header
 '0' (30h): Reserved
 '0' (30h): Message receiver is the controller.
 Monitor ID: Indicate a replying Monitor ID.
 Ex.) When this byte is set to 'A', replying monitor's ID is '1'.
 'B' (42h): Message type is "Command reply".
 '0'-'A' (30h,41h): Message length (10byte)

Message

STX (02h): Start of Message
 'C'-'B'-'0'-'B' (43h, 42h, 30h, 42h): Power Save Mode Reply
 '0'-'4' (30h, 34h): Auto Standby Time Read
 TIME: AUTO STANDBY TIME (sec.)
 00h (30h, 30h) - 78h (37h, 38h): 1 (5dec.) - 120 (600sec.)
 ETX (03h): End of Message

Check code

BCC: Block Check Code
 Refer to the section 4.3 "Check code" for a BCC calculation.

Delimiter

CR (0Dh): End of packet

19.4 Auto Standby Time Write

This command is used in order to write the setting of Auto Standby Time.

1) The controller requests the monitor to write Time.

Header	Message	Check code	Delimiter
SOH-'0'-Monitor ID-'0'- 'A'-'0'-'A'	STX-'C'-'A'-'0'-'B'-'0'-'5'-TIME-ETX	BCC	CR

Header

SOH (01h): Start of Header
 '0' (30h): Reserved
 Monitor ID: Specify the Monitor ID of which you want to change a setting.
 Ex.) If Monitor ID is '1', specify 'A'.
 '0' (30h): Message sender is the controller.
 'A' (41h): Message type is "Command".
 '0'-'A'(30h,41h): Message length (10byte)

Message

STX (02h): Start of Message
 'C'-'A'-'0'-'B' (43h, 41h, 30h, 42h): Power Save Mode command
 '0'-'5' (30h, 35h): Auto Standby Time Write
 TIME: AUTO STANDBY TIME (sec.)
 00h (30h, 30h) - 78h (37h, 38h): 1 (5dec.) - 120 (600sec.)
 ETX (03h): End of Message

Check code

BCC: Block Check Code
 Refer to the section 4.3 "Check code" for a BCC calculation.

Delimiter

CR (0Dh): End of packet

2) The monitor replies a written in result.

Header	Message	Check code	Delimiter
SOH-'0'-'0'-Monitor ID- 'B'-'0'-'A'	STX-'C'-'B'-'0'-'B'-'0'-'5'-ST-ETX	BCC	CR

Header

SOH (01h): Start of Header
 '0' (30h): Reserved
 '0' (30h): Message receiver is the controller.
 Monitor ID: Indicate a replying Monitor ID.
 Ex.) When this byte is set to 'A', replying monitor's ID is '1'.
 'B' (42h): Message type is "Command reply".
 '0'-'A'(30h,41h): Message length (10byte)

Message

STX (02h): Start of Message
 'C'-'B'-'0'-'B' (43h, 42h, 30h, 42h): Power Save Mode Reply
 '0'-'5' (30h, 35h): Auto Standby Time Write
 ST: Error Status
 No Error : 00h (30h, 30h)
 Error : 01h (30h, 31h)
 ETX (03h): End of Message

Check code

BCC: Block Check Code
 Refer to the section 4.3 "Check code" for a BCC calculation.

Delimiter

CR (0Dh): End of packet

20. Setting Copy

20.1 Setting Copy Read

This command is used in order to read the Setting Copy.

- 1) The controller requests the monitor to read Setting Copy

Header	Message	Check code	Delimiter
SOH-'0'-Monitor ID-'0'-'A'-'0'-'8'	STX-'C'-'A'-'0'-'9'-'0'-'0'-ETX	BCC	CR

Header

SOH (01h): Start of Header
'0' (30h): Reserved
Monitor ID: Specify the Monitor ID of which you want to change a setting.
Ex.) If Monitor ID is '1', specify 'A'.
'0' (30h): Message sender is the controller.
'A' (41h): Message type is "Command".
'0'-'8' (30h, 38h): Message length (8byte)

Message

STX (02h): Start of Message
'C'-'A'-'0'-'9' (43h,41h,30h,39h): Setting Copy command
'0'-'0' (30h,30h): Target Read
ETX (03h): End of Message

Check code

BCC: Block Check Code
Refer to the section 4.3 "Check code" for a BCC calculation.

Delimiter

CR (0Dh): End of packet

- 2) The monitor replies Setting Copy to the controller.

Header	Message	Check code	Delimiter
SOH-'0'-'0'-Monitor ID-'B'-'1'-'0'	STX-'C'-'B'-'0'-'9'-'0'-'0'-T4-T3-T2-T1-ETX	BCC	CR

Header

SOH (01h): Start of Header
'0' (30h): Reserved
'0' (30h): Message receiver is the controller.
Monitor ID: Indicate a replying Monitor ID.
Ex.) When this byte is set to 'A', replying monitor's ID is '1'.
'B' (42h): Message type is "Command reply".
'1'-'0' (31h,30h): Message length (16byte)

Message

STX (02h): Start of Message
'C'-'B'-'0'-'9' (43h, 42h, 30h, 39h): Setting Copy Reply
'0'-'0' (30h, 30h): Target Read
T1 - T4 : 00h (30h, 30h) - FFh (46h, 46h)
T1 : Setting Copy Target 4 (Bit12-Bit15)
T2 : Setting Copy Target 3 (Bit8-Bit11)
T3 : Setting Copy Target 2 (Bit4-Bit7)
T4 : Setting Copy Target 1 (Bit0-Bit3)
Bit0: ALL INPUT
Bit1: PICTURE
Bit2: ADJUST
Bit3: AUDIO
Bit4: SCHEDULE
Bit5: PIP

Bit6: OSD
Bit7: MULTI DISP
Bit8: PROTECT
Bit9: EXT-CTRL
Bit10: ADVANCED
Bit11: ADVANCED2
Bit12: HTTP
Bit13: Reserve
Bit14: Reserve
Bit15: Reserve

Ex.) Setting the following value for T4

Bit0: ALL INPUT is OFF (0).

Bit1: PICTURE is OFF (0).

Bit2: ADJUST is ON (1).

Bit3: AUDIO is ON (1).

Step 1: Put above bit in following order.

Bit3-Bit2-Bit1-Bit0

Value: 1100

Step 2: Write the value of Step 1 by a hexadecimal number.

Value: 0Ch

Step 3: Encode the value of Step 2 to ASCII characters.

Value: '0' and 'C' (30h and 43h)

ETX (03h): End of Message

Check code

BCC: Block Check Code

Refer to the section 4.3 "Check code" for a BCC calculation.

Delimiter

CR (0Dh): End of packet

20.2 Setting Copy Write

This command is used in order to write the setting of Setting Copy.

1) The controller requests the monitor to write Setting Copy.

Header	Message	Check code	Delimiter
SOH-'0'-Monitor ID-'0'-'A'-'1'-'0'	STX-'C'-'A'-'0'-'9'-'0'-'1'-'0'-T4-T3-T2-T1-ETX	BCC	CR

Header

SOH (01h): Start of Header
 '0' (30h): Reserved
 Monitor ID: Specify the Monitor ID of which you want to change a setting.
 Ex.) If Monitor ID is '1', specify 'A'.
 '0' (30h): Message sender is the controller.
 'A' (41h): Message type is "Command".
 '1'-'0' (31h,30h): Message length

Message

STX (02h): Start of Message
 'C'-'A'-'0'-'9' (43h,41h,30h,39h): Setting Copy command
 '0'-'1' (30h,31h): Target Write
 T1 - T4 : 00h (30h, 30h) - FFh (46h, 46h)
 T1 : Setting Copy Target 4 (Bit12-Bit15)
 T2 : Setting Copy Target 3 (Bit8-Bit11)
 T3 : Setting Copy Target 2 (Bit4-Bit7)
 T4 : Setting Copy Target 1 (Bit0-Bit3)
 Bit0: ALL INPUT
 Bit1: PICTURE
 Bit2: ADJUST
 Bit3: AUDIO
 Bit4: SCHEDULE
 Bit5: PIP
 Bit6: OSD
 Bit7: MULTI DISP
 Bit8: PROTECT
 Bit9: EXT-CTRL
 Bit10: ADVANCED
 Bit11: ADVANCED2
 Bit12: HTTP
 Bit13: Reserve
 Bit14: Reserve
 Bit15: Reserve
 Ex.) Setting the following value for T4
 Bit0: ALL INPUT is OFF (0).
 Bit1: PICTURE is OFF (0).
 Bit2: ADJUST is ON (1).
 Bit3: AUDIO is ON (1).
 Step 1: Put above bit in following order.
 Bit3-Bit2-Bit1-Bit0
 Value: 1100
 Step 2: Write the value of Step 1 by a hexadecimal number.
 Value: 0Ch
 Step 3: Encode the value of Step 2 to ASCII characters.
 Value: '0' and 'C' (30h and 43h)
 ETX (03h): End of Message

Check code

BCC: Block Check Code
 Refer to the section 4.3 "Check code" for a BCC calculation.

Delimiter

CR (0Dh): End of packet

2) The monitor replies a written in result.

Header	Message	Check code	Delimiter
SOH-'0'-'0'-Monitor ID- 'B'-'0'-'A'	STX-'C'-'B'-'0'-'9'-'0'-'1'-ST-ETX	BCC	CR

Header

SOH (01h): Start of Header
 '0' (30h): Reserved
 '0' (30h): Message receiver is the controller.
 Monitor ID: Indicate a replying Monitor ID.
 Ex.) When this byte is set to 'A', replying monitor's ID is '1'.
 'B' (42h): Message type is "Command reply".
 '0'-'A'(30h,41h): Message length (10byte)

Message

STX (02h): Start of Message
 'C'-'B'-'0'-'9' (43h, 42h, 30h, 39h): Setting Copy Reply
 '0'-'1' (30h, 30h): Target Write
 ST: Status
 No Error : 00h (30h, 30h)
 Error : 01h (30h, 31h)
 ETX (03h): End of Message

Check code

BCC: Block Check Code
 Refer to the section 4.3 "Check code" for a BCC calculation.

Delimiter

CR (0Dh): End of packet

20.3 Setting Copy Start

This command is used in order to start Setting Copy.

- 1) The controller requests the monitor to write Setting Copy Start.

Header	Message	Check code	Delimiter
SOH-'0'-Monitor ID-'0'-'A'-'0'-'8'	STX-'C'-'A'-'0'-'9'-'0'-'2'-ETX	BCC	CR

Header

SOH (01h): Start of Header
 '0' (30h): Reserved
 Monitor ID: Specify the Monitor ID of which you want to change a setting.
 Ex.) If Monitor ID is '1', specify 'A'.
 '0' (30h): Message sender is the controller.
 'A' (41h): Message type is "Command".
 '0'-'8' (30h, 38h): Message length (8byte)

Message

STX (02h): Start of Message
 'C'-'A'-'0'-'9' (43h,41h,30h,39h): Setting Copy command
 '0'-'2' (30h,32h): Start
 ETX (03h): End of Message

Check code

BCC: Block Check Code
 Refer to the section 4.3 "Check code" for a BCC calculation.

Delimiter

CR (0Dh): End of packet

- 2) The monitor replies to the controller.

Header	Message	Check code	Delimiter
SOH-'0'-'0'-Monitor ID-'B'-'0'-'A'	STX-'C'-'B'-'0'-'9'-'0'-'2'-ST-ETX	BCC	CR

Header

SOH (01h): Start of Header
 '0' (30h): Reserved
 '0' (30h): Message receiver is the controller.
 Monitor ID: Indicate a replying Monitor ID.
 Ex.) When this byte is set to 'A', replying monitor's ID is '1'.
 'B' (42h): Message type is "Command reply".
 '0'-'A' (30h,41h): Message length (10byte)

Message

STX (02h): Start of Message
 'C'-'B'-'0'-'9' (43h, 42h, 30h, 39h): Setting Copy Reply
 '0'-'2' (30h, 30h): Start
 ST: Status
 No Error: 00h (30h, 30h)
 Error : 01h (30h, 31h)
 ETX (03h): End of Message

Check code

BCC: Block Check Code
 Refer to the section 4.3 "Check code" for a BCC calculation.

Delimiter

CR (0Dh): End of packet

21. Security Enable

21.1 Security Enable Read

This command is used in order to read the Security Enable.

- 1) The controller requests the monitor to read Security Enable

Header	Message	Check code	Delimiter
SOH-'0'-Monitor ID-'0'-'A'-'0'-'8'	STX-'C'-'A'-'0'-'C'-'0'-'2'-ETX	BCC	CR

Header

SOH (01h): Start of Header
'0' (30h): Reserved
Monitor ID: Specify the Monitor ID of which you want to change a setting.
Ex.) If Monitor ID is '1', specify 'A'.
'0' (30h): Message sender is the controller.
'A' (41h): Message type is "Command".
'0'-'8'(30h, 38h): Message length (8byte)

Message

STX (02h): Start of Message
'C'-'A'-'0'-'C' (43h, 41h, 30h, 43h): Security password Command
'0'-'2' (30h, 32h): Enable Read
ETX (03h): End of Message

Check code

BCC: Block Check Code
Refer to the section 4.3 "Check code" for a BCC calculation.

Delimiter

CR (0Dh): End of packet

- 2) The monitor replies Security Enable to the controller.

Header	Message	Check code	Delimiter
SOH-'0'-'0'-Monitor ID-'B'-'0'-'A'	STX-'C'-'B'-'0'-'C'-'0'-'2'-EN-ETX	BCC	CR

Header

SOH (01h): Start of Header
'0' (30h): Reserved
'0' (30h): Message receiver is the controller.
Monitor ID: Indicate a replying Monitor ID.
Ex.) When this byte is set to 'A', replying monitor's ID is '1'.
'B' (42h): Message type is "Command reply".
'0'-'A'(30h,41h): Message length (10byte)

Message

STX (02h): Start of Message
'C'-'B'-'0'-'C'-'0'-'2' (43h, 42h, 30h, 41h, 30h, 32h): Get Security Enable Disable Reply
EN: Status
00h: Disable
01h: Enable
ETX (03h): End of Message

Check code

BCC: Block Check Code
Refer to the section 4.3 "Check code" for a BCC calculation.

Delimiter

CR (0Dh): End of packet

21.2 Security Enable Write

This command is used in order to write the setting of Security Enable.

- 1) The controller requests the monitor to set Security password.

Header	Message	Check code	Delimiter
SOH-'0'-Monitor ID-'0'-'A'-'1'-'C'	STX-'C'-'A'-'0'-'C'-'0'-'1'-'ENA-'0'-'0'-PWD1-...-PWD16-ETX	BCC	CR

Header

SOH (01h): Start of Header
 '0' (30h): Reserved
 Monitor ID: Specify the Monitor ID of which you want to change a setting.
 Ex.) If Monitor ID is '1', specify 'A'.
 '0' (30h): Message sender is the controller.
 'A' (41h): Message type is "Command".
 '1'-'C'(31h,43h): Message length (28byte)

Message

STX (02h): Start of Message
 'C'-'A'-'0'-'C' (43h, 41h, 30h, 43h): Security Password Command
 '0'-'1' (30h, 31h): Enable Write
 ENA: Enable/Disable
 00h (30h, 30h): Disable
 01h (30h, 31h): Enable
 '0'-'0' (30h, 30h): Reserved
 PWD1 - PWD16: Password data
 > The password data is encoded as the following procedure.
 Ex.) In the case of password data "1234"
 Step1: Password data is handled as character code.
 Example:
 "1234" -> 31h 32h 33h 34h (ASCII)
 Step2: The hexadecimal value of each original character is encoded as two ASCII characters representing the hex value.
 Example:
 31h 32h 33h 34h -> '3'-'1'-'3'-'2'-'3'-'3'-'3'-'4'
 Step3: Password data is handled as character code once again.
 Example:
 '3'-'1'-'3'-'2'-'3'-'3'-'3'-'4' -> 33h 31h 33h 32h 33h 33h 33h 34h (ASCII)
 Step4: The hexadecimal value of each original character is encoded as two ASCII characters representing the value.
 Example:
 33h 31h 33h 32h 33h 33h 33h 34h
 -> '3'-'3'-'3'-'1'-'3'-'3'-'3'-'2'-'3'-'3'-'3'-'3'-'3'-'3'-'3'-'4'
 Result: The following data is assigned to PWD1-PWD16.
 33h 33h 33h 31h 33h 33h 33h 32h 33h 33h 33h 33h 33h 33h 33h 34h
 ETX (03h): End of Message

Check code

BCC: Block Check Code
 Refer to the section 4.3 "Check code" for a BCC calculation.

Delimiter

CR (0Dh): End of packet

- 2) The monitor replies a written in result.

Header	Message	Check code	Delimiter
SOH-'0'-'0'-Monitor ID-'B'-'0'-'A'	STX-'C'-'B'-'0'-'C'-'0'-'1'-ST-ETX	BCC	CR

Header

SOH (01h): Start of Header

'0' (30h): Reserved
'0' (30h): Message receiver is the controller.
Monitor ID: Indicate a replying Monitor ID.
 Ex.) When this byte is set to 'A', replying monitor's ID is '1'.
'B' (42h): Message type is "Command reply".
'0'-'A'(30h,41h): Message length (10byte)

Message

STX (02h): Start of Message
'C'-'B'-'0'-'C' (43h, 42h, 30h, 43h): Security password Reply Command
'0'-'1' (30h, 31h): Enable Write
ST: Error Status
 00h: No Error
 01h: Error
ETX (03h): End of Message

Check code

BCC: Block Check Code
 Refer to the section 4.3 "Check code" for a BCC calculation.

Delimiter

CR (0Dh): End of packet

22. LAN MAC Address

22.1 LAN MAC Address Read

This command is used in order to read the MAC Address.

- 1) The controller requests the monitor to read MAC Address

Header	Message	Check code	Delimiter
SOH-'0'-Monitor ID-'0'-'A'-'0'-'8'	STX-'C'-'2'-'2'-'A'-'0'-'2'-ETX	BCC	CR

Header

SOH (01h) : Start of Header
'0' (30h) : Reserved
Monitor ID: Specify the Monitor ID from which you want to get status.
 Ex.) If Monitor ID is '1', specify 'A'.
'0' (30h) : Message sender is the controller.
'A' (41h) : Message Type is "Command".
'0'-'8' (30h, 38h) : Message length is 8 bytes.

Message

STX (02h): Start of Message
'C'-'2'-'2'-'A': LAN read command.
'0'-'2': MAC Address
ETX (03h): End of Message

Check code

BCC: Block Check Code
Refer to the section 4.3 "Check code" for a BCC calculation.

Delimiter

CR (0Dh): End of packet

- 2) The monitor replies MAC Address to the controller.

Header	Message	Check code	Delimiter
SOH-'0'-'0'-Monitor ID-'B'-LN(H)-LN(L)	STX-'C'-'3'-'2'-'A'-RC-'0'-'2'-IPV-MAC(0)-...-MAC(n)-ETX	BCC	CR

Header

SOH (01h): Start of Header
'0' (30h): Reserved
'0' (30h): Message receiver is the controller.
Monitor ID: Indicate a replying Monitor ID.
 Ex.) When this byte is set to 'A', the replying Monitor ID is '1'.
'B' (42h): Message Type is "Command reply".
LN(H)-LN(L): Message length (byte length), from STX to ETX

Message

STX(02h):Start of Message
'C'-'3'-'2'-'A': LAN read reply command.
RC: Reply result Code
'0'-'0' (30h, 30h): Normal
'F'-'F' (46h, 46h): Abnormal
'0'-'2': MAC Address
IPV: IPv4 or IPv6
'0'-'4' (30h, 34h): IPv4
'0'-'6' (30h, 36h): IPv6
MAC(0-n): MAC Address
 In the case of IPv4 -> n = 4

ETX (03h): End of Message

Check code

BCC: Block Check Code

Refer to the section 4.3 "Check code" for a BCC calculation.

Delimiter

CR (0Dh): End of packet

23. Proof of Play

23.1 Set Proof of Play Operation Mode

This command is used in order to set Operation mode of Proof of Play.

- 1) The controller requests the monitor to set Operation mode of Proof of Play.

Header	Message	Check code	Delimiter
SOH-'0'-Monitor ID-'0'-'A'-'0'-'A'	STX-'C'-'A'-'1'-'5'-'0'-'0'-MD-ETX	BCC	CR

Header

SOH (01h) : Start of Header
'0' (30h) : Reserved
Monitor ID: Specify the Monitor ID from which you want to get status.
 Ex.) If Monitor ID is '1', specify 'A'.
'0' (30h) : Message sender is the controller.
'A' (41h) : Message Type is "Command".
'0'-'A' (30h, 41h) : Message length is 10 bytes.

Message

STX (02h): Start of Message
'C'-'A'-'1'-'5': Proof of Play command
'0'-'0' (30h,30h): Set Proof of Play Operation Mode command
MD : Mode of Proof of Play.
'0'-'0'(30h, 30h): Stop
'0'-'1'(30h, 31h): Start
'0'-'2'(30h, 32h): Clear Log data
ETX (03h): End of Message

Check code

BCC: Block Check Code
Refer to the section 4.3 "Check code" for a BCC calculation.

Delimiter

CR (0Dh): End of packet

- 2) The monitor replies the result of set Operation mode to the controller.

Header	Message	Check code	Delimiter
SOH-'0'-Monitor ID-'0'-'B'-'0'-'A'	STX-'C'-'B'-'1'-'5'-'0'-'0'-ST-ETX	BCC	CR

Header

SOH (01h) : Start of Header
'0' (30h) : Reserved
Monitor ID: Specify the Monitor ID from which you want to get status.
 Ex.) If Monitor ID is '1', specify 'A'.
'0' (30h) : Message sender is the controller.
'A' (41h) : Message Type is "Command".
'0'-'A' (30h, 41h) : Message length is 10 bytes.

Message

STX (02h): Start of Message
'C'-'B'-'1'-'5': Proof of Play reply command
'0'-'0' (30h,30h): Set Proof of Play Operation Mode command
ST: Status
'0'-'0'(30h, 30h): No Error
'0'-'1'(30h, 31h): Error
'0'-'2'(30h, 32h): Already Start/Stop/Clear

ETX (03h): End of Message

Check code

BCC: Block Check Code

Refer to the section 4.3 "Check code" for a BCC calculation.

Delimiter

CR (0Dh): End of packet

23.2 Get Proof of Play Current

This command is used in order to get Current log data of Proof of Play.

Note : Proof of Play information cannot be read from the display when it is in OFF state. The display must be fully powered on to read Proof of Play information. Also the display does not continue to create any new logs while it is in OFF state.

1) The controller requests the monitor to get Current log data of Proof of Play.

Header	Message	Check code	Delimiter
SOH-'0'-Monitor ID- '0'-'A'-'0'-'8'	STX-'C'-'A'-'1'-'5'-'0'-'1'-ETX	BCC	CR

Header

SOH (01h) : Start of Header
 '0' (30h) : Reserved
 Monitor ID: Specify the Monitor ID from which you want to get status.
 Ex.) If Monitor ID is '1', specify 'A'.
 '0' (30h) : Message sender is the controller.
 'A' (41h) : Message Type is "Command".
 '0'-'8' (30h, 38h) : Message length is 8 bytes.

Message

STX (02h) : Start of Message
 'C'-'A'-'1'-'5': Proof of Play command
 '0'-'1' (30h,31h) : Get Current log of Proof of Play command
 ETX (03h) : End of Message

Check code

BCC: Block Check Code
 Refer to the section 4.3 "Check code" for a BCC calculation.

Delimiter

CR (0Dh) : End of packet

2) The monitor replies the result of Current log data to the controller.

Header	Message	Check code	Delimiter
SOH-'0'-Monitor ID- '0'-'B'-'3'-'4'	STX-'C'-'B'-'1'-'5'-'0'-'1'-ST-CNH- CNL-Data(0)-Data(1)-Data(2)--- Data(18)-ETX	BCC	CR

Header

SOH (01h) : Start of Header
 '0' (30h) : Reserved
 Monitor ID: Specify the Monitor ID from which you want to get status.
 Ex.) If Monitor ID is '1', specify 'A'.
 '0' (30h) : Message sender is the controller.
 'A' (41h) : Message Type is "Command".
 '3'-'4' (33h, 34h) : Message length is 52 bytes.

Message

STX (02h) : Start of Message
 'C'-'B'-'1'-'5': Proof of Play reply command
 '0'-'1' (30h,31h) : Get Current log of Proof of Play command
 ST: Status
 No Error : 00h (30h, 30h)
 Error: 01h (30h, 31h)
 CNH: Current log data Number (High byte)

```

CNL: Current log data Number (Low byte)
'0','0','0','1' -'F','F','F','F' (30h, 30h, 30h, 31h - 46h, 46h, 46h, 46h) :1 - 65535
Data(0)-Data(18): Data of Proof of Play
-----
Log Data of Proof of Play : Data(0)-Data(18)
Data(0): Check INPUT PICTURE
    Same as VCP(Page11 06H Input source) reply parameter.
    Refer to Item "INPUT" on page 41.
Data(1)-Data(4) : Check Input Signal
'0'-'0'-'0'-'0'-'0'-'0'-'0'-'0' (30h,30h,30h,30h,30h,30h,30h,30h):No signal
'F'-'F'-'F'-'F'-'F'-'F'-'F'-'F' (46h,46h,46h,46h,46h,46h,46h,46h):Invalid signal
'*'-'*'-'*'-'*'-'*'-'*'-'*'-'*' (**h,**h,**h,**h,**h,**h,**h,**h):Input signal
    Ex ) 1920 x 1080
        '0'-'7'-'8'-'0'-'0'-'4'-'3'-'8' : 1920(0768h) x 1080(0438h)
Data(5) : Check INPUT AUDIO
    Same as VCP(Page2 2EH Select Sound Input) reply parameter.
    Refer to Item "AUDIO INPUT" on page 33.
Data(6) : Check with or without Audio
'0'-'0'(30h,30h): Audio in
'0'-'1'(30h,31h): No Audio in
'0'-'2'(30h,32h): N/A
Data(7) : Check status (Picture)
'0'-'0'(30h,30h): Normal Picture
'0'-'1'(30h,31h): No Picture
Data(8) : Check status (Audio)
'0'-'0'(30h,30h): Normal Audio
'0'-'1'(30h,31h): No Audio
Data(9)-Data(10) : Year
'*'-'*'-'*'-'*' (**h,**h,**h,**h):0~65535(0000h~FFFFh)
    Ex ) 2014
        '0'-'7'-'D'-'E' : 2014(07DEh)
Data(11) : month
'0'-'1' (30h,31h): January
'0'-'2' (30h,31h): February
    |
'0'-'B' (30h,31h): November
'0'-'C' (30h,31h): December
Data(12) : day
'*'-'*' (**h,**h):1~31(01h~1Fh)
Date(13) : hour
'*'-'*' (**h,**h):0~23(00h~17h)
Date(14) :min
'*'-'*' (**h,**h):0~59(00h~3Bh)
Data(15) : sec
'*'-'*' (**h,**h):0~59(00h~3Bh)
Data(16) : Extention parameter
'0'-'0'(30h,30h): Normal Proof of Play event
'0'-'1'(30h,31h): Proof of Play event is "last power on time" *1)
'0'-'2'(30h,32h): Reserved
'1'-'0'(31h,30h): MEDIA PLYER is stop
'1'-'1'(31h,31h): MEDIA PLAYER is start
'1'-'2'(31h,32h): MEDIA PLAYER is pause
'1'-'3'(31h,33h): MEDIA PLAYER error occur
'1'-'4'(31h,34h) - '1'-'F'(31h,46h): Reserved
'2'-'0'(32h,30h): Contents Copy from USB
'2'-'1'(32h,31h): Contents Copy form network folder
'2'-'2'(32h,32h) - '2'-'F'(32h,46h): Reserved

```

'3'-'0'(33h,30h): Contents Copy Success
'3'-'1'(33h,31h): Contents Copy Error (No media)
'3'-'2'(33h,32h): Contents Copy Error (Connect error)
'3'-'3'(33h,33h): Contents Copy Error (Out of disk space)
'3'-'4'(33h,34h): Contents Copy Error (Read/Write error)
'3'-'5'(32h,35h) - '3'-'F'(33h,46h): Reserved
'4'-'0'(34h,30h): Human detected (Human sensor Status) *2)
'4'-'1'(34h,31h): Human detect cleared (Human Sensor Status) *2)
'4'-'2'(34h,32h) - '4'-'F'(34h,46h): Reserved
*1: After Power ON, the first log is "Data16=01h".
*2: Save the Human Sensor status every 30 minutes.
Data(17)-Data(18) : Reserve(future use : always '0'-0'-0'-0'-0'-0')

ETX (03h): End of Message

Check code

BCC: Block Check Code
Refer to the section 4.3 "Check code" for a BCC calculation.

Delimiter

CR (0Dh): End of packet

23.3 Get Proof of Play Status

This command is used in order to get Proof of Play Status.

- 1) The controller requests the monitor to get status of Proof of Play.

Header	Message	Check code	Delimiter
SOH-'0'-Monitor ID-'0'-'A'-'0'-'8'	STX-'C'-'A'-'1'-'5'-'0'-'2'-ETX	BCC	CR

Header

SOH (01h) : Start of Header
 '0' (30h) : Reserved
 Monitor ID: Specify the Monitor ID from which you want to get status.
 Ex.) If Monitor ID is '1', specify 'A'.
 '0' (30h) : Message sender is the controller.
 'A' (41h) : Message Type is "Command".
 '0'-'8' (30h, 38h) : Message length is 8 bytes.

Message

STX (02h): Start of Message
 'C'-'A'-'1'-'5'
 6': Proof of Play command
 '0'-'2' (30h,32h): Get Proof of Play Status command
 ETX (03h): End of Message

Check code

BCC: Block Check Code
 Refer to the section 4.3 "Check code" for a BCC calculation.

Delimiter

CR (0Dh): End of packet

- 2) The monitor replies the status of Proof of Play to the controller.

Header	Message	Check code	Delimiter
SOH-'0'-Monitor ID-'0'-'B'-'1'-'4'	STX-'C'-'B'-'1'-'5'-'0'-'2'-ST1-ST2-ST3-ST4-ST5-ST6-ETX	BCC	CR

Header

SOH (01h) : Start of Header
 '0' (30h) : Reserved
 Monitor ID: Specify the Monitor ID from which you want to get status.
 Ex.) If Monitor ID is '1', specify 'A'.
 '0' (30h) : Message sender is the controller.
 'A' (41h) : Message Type is "Command".
 '1'-'4' (31h, 34h) : Message length is 20 bytes.

Message

STX (02h): Start of Message
 'C'-'B'-'1'-'5': Proof of Play reply command
 '0'-'2' (30h,32h): Get Proof of Play status command
 ST1: Error status
 00h (30h, 30h): No Error
 01h (30h, 30h): Memory full (some date has been lost)
 02h (30h, 30h): other error (other error has priority ver 01h error)
 ST2: Total Number-High byte (How many log data items are currently used.)
 ST3: Total Number-Low byte (How many log data items are currently used.)
 '0','0','0','0' - 'F','F','F','F' (30h,30h,30h,30h - 46h,46h,46h,46h): 0-65535

ST4: Maximum Number-High byte (Maximum possible number of log data items)
ST5: Maximum Number-Low byte (Maximum possible number of log data items)
 '0','0','0','0' - 'F','F','F','F' (30h,30h,30h,30h - 46h,46h,46h,46h): 0 - 65535
ST6: Current Proof of Play status.
 Stop: 00h (30h, 30h)
 Start: 01h (30h, 31h)
ETX (03h): End of Message

Check code

BCC: Block Check Code
Refer to the section 4.3 "Check code" for a BCC calculation.

Delimiter

CR (0Dh): End of packet

23.4 Get Proof of Play Number to Number

This command is used in order to get Proof of Play number to number log.

- 1) The controller requests the monitor to get Number to Number log of Proof of Play.

Header	Message	Check code	Delimiter
SOH-'0'-Monitor ID-'0'-'A'-'1'-'0'	STX-'C'-'A'-'1'-'5'-'0'-'3'-BNS(H)-BNS(L)-BNE(H)-BNE(L)-ETX	BCC	CR

Header

SOH (01h) : Start of Header
 '0' (30h) : Reserved
 Monitor ID: Specify the Monitor ID from which you want to get status.
 Ex.) If Monitor ID is '1', specify 'A'.
 '0' (30h) : Message sender is the controller.
 'A' (41h) : Message Type is "Command".
 '1'-'0' (31h, 30h) : Message length is 16 bytes.

Message

STX (02h): Start of Message
 'C'-'A'-'1'-'5': Proof of Play command
 '0'-'3' (30h,33h): Get Proof of Play Number to Number log command
 BNS(H): Block Number of Start (High byte)
 BNS(L): Block Number of Start (Low byte)
 BNE(H): Block Number of Stop (High byte)
 BNE(L): Block Number of Stop (Low byte)
 ETX (03h): End of Message

Check code

BCC: Block Check Code
 Refer to the section 4.3 "Check code" for a BCC calculation.

Delimiter

CR (0Dh): End of packet

- 2) The monitor replies the number to number log of Proof of Play to the controller.

Header	Message	Check code	Delimiter
SOH-'0'-Monitor ID-'0'-'B'-'3'-'4'	STX-'C'-'B'-'1'-'5'-'0'-'3'- LNR(H)-LNR(L)-Data(0)-Data(1)-Data(2) ---Data(18) -ETX	BCC	CR

* A reply returns data in order from specified Number to specified Number.

Ex) Number to Number: 1 to 6

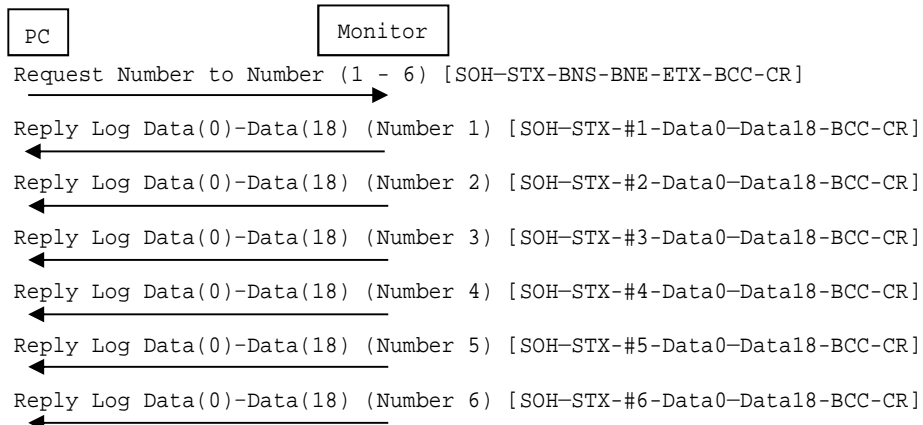

Header

SOH (01h) : Start of Header

'0' (30h) : Reserved
Monitor ID: Specify the Monitor ID from which you want to get status.
 Ex.) If Monitor ID is '1', specify 'A'.
'0' (30h) : Message sender is the controller.
'A' (41h) : Message Type is "Command".
'3'-'4' (33h, 36h) : Message length is 38 bytes.

Message

STX (02h): Start of Message
'C'-'B'-'1'-'5': Proof of Play reply command
'0'-'3' (30h,33h): Get Proof of Play Number to Number log command
LNR (H): log number being returned (High byte)
LNR (L): log number being returned (Low byte)
Data(0)-Data(12): Log Data of Proof of Play of STOP (26byte) : Same as "Get Proof of Play Current"
 * Refer to "Get Proof of Play Current"
ETX (03h): End of Message

Check code

BCC: Block Check Code
Refer to the section 4.3 "Check code" for a BCC calculation.

Delimiter

CR (0Dh): End of packet

24. Setting Lock of COMPUTE MODULE

24.1 Setting Lock Control

This command sets the condition of setting lock function of COMPUTE MODULE to "ON" or "OFF". If setting lock password 1st to 4th are matched with monitor resisted password, then this command is executed, and reply no error status.

If codes aren't matched with them then setting isn't changed, and reply error status.

- 1) The controller requests the monitor to set the condition of setting lock.

Header	Message	Check code	Delimiter
SOH-'0'-MonitorID-'0'-'A'-'1'-'0'	STX-'C'-'A'-'1'-'B'-EN-P1-P2-P3-P4-ETX	BCC	CR

Header

SOH (01h): Start of Header

'0' (30h): Reserved

Monitor ID: Specify the Monitor ID of which you want to change a setting.

Ex.) If Monitor ID is '1', specify 'A'.

'0' (30h): Message sender is the controller.

'A' (41h): Message type is "Command".

'1'-'0'(31h, 30h): Message length

Message

STX (02h): Start of Message

'C'-'A'-'1'-'B' (43h, 41h, 31h, 42h): Service Lock Control command

EN: Enable /Disable

'0'-'0'(30h, 30h): OFF

'0'-'1'(30h, 31h): ON

P1-P2-P3-P4: Lock condition control data

P1: Security Pass code 1st

'0'-'0'(30h, 30h): "0"

|

'0'-'9'(30h, 39h): "9"

P2: Security Pass code 2nd

'0'-'0'(30h, 30h): "0"

|

'0'-'9'(30h, 39h): "9"

P3: Security Pass code 3rd

'0'-'0'(30h, 30h): "0"

|

'0'-'9'(30h, 39h): "9"

P4: Security Pass code 4th

'0'-'0'(30h, 30h): "0"

|

'0'-'9'(30h, 39h): "9"

ETX (03h): End of Message

Check code

BCC: Block Check Code

Refer to the section 4.3 "Check code" for a BCC calculation.

Delimiter

CR (0Dh): End of packet

2) The monitor replies the result to the controller.

Header	Message	Check code	Delimiter
SOH-'0'-'0'-Monitor ID-'B'-'0'-'A'	STX-'C'-'B'-'1'-'B'-ST-EN-ETX	BCC	CR

Header

SOH (01h): Start of Header
 '0' (30h): Reserved
 '0' (30h): Message receiver is the controller.
 Monitor ID: Indicate a replying Monitor ID.
 Ex.) When this byte is set to 'A', the replying Monitor ID is '1'.
 'B' (42h): Message type is "Command reply".
 '0'-'A'(30h, 41h): Message length

Message

STX (02h): Start of Message
 'C'-'B'-'1'-'B' (43h, 42h, 31h, 42h): Security Lock Control reply command
 ST: Status
 '0'-'0'(30h, 30h): No error
 '0'-'1'(30h, 31h): Error
 EN: Enable /Disable
 '0'-'0'(30h, 30h): OFF
 '0'-'1'(30h, 31h): ON
 ETX (03h): End of Message

Check code

BCC: Block Check Code
 Refer to the section 4.3 "Check code" for a BCC calculation.

Delimiter

CR (0Dh): End of packet

25. Emergency Contents

This function which plays files in the EMERGENCY CONTENTS folder automatically using MEDIA PLAYER function.

During playing, a display prohibits operation except power off.

Create "EMERGENCY CONTENTS" folder in a route folder.

"Display command" starts playing, and "Delete command" stops playing.

25.1 Emergency Contents Display

This command is used in order to display Emergency Contents.

1) The controller requests the monitor to display Emergency Contents.

Header	Message	Check code	Delimiter
SOH-'0'-Monitor ID-'0'-'A'-'0'-'8'	STX-'C'-'A'-'1'-'F'-'0'-'1'-ETX	BCC	CR

Header

SOH (01h): Start of Header

'0' (30h): Reserved

Monitor ID: Specify the Monitor ID of which you want to change a setting.

Ex.) If Monitor ID is '1', specify 'A'.

'0' (30h): Message sender is the controller.

'A' (41h): Message type is "Command".

'0'-'8'(30h, 38h): Message length (8byte)

Message

STX (02h): Start of Message

'C'-'A'-'1'-'F' (43h, 41h, 31h, 46h): Emergency Contents Command

'0'-'1' (30h, 32h): Display

ETX (03h): End of Message

Check code

BCC: Block Check Code

Refer to the section 4.3 "Check code" for a BCC calculation.

Delimiter

CR (0Dh): End of packet

2) The monitor replies Security Enable to the controller.

Header	Message	Check code	Delimiter
SOH-'0'-'0'-Monitor ID-'B'-'0'-'A'	STX-'C'-'B'-'1'-'F'-'0'-'1'-ST-ETX	BCC	CR

Header

SOH (01h): Start of Header

'0' (30h): Reserved

'0' (30h): Message receiver is the controller.

Monitor ID: Indicate a replying Monitor ID.

Ex.) When this byte is set to 'A', replying monitor's ID is '1'.

'B' (42h): Message type is "Command reply".

'0'-'A'(30h,41h): Message length (10byte)

Message

STX (02h): Start of Message

'C'-'B'-'1'-'F' (43h, 42h, 31h, 46h): Emergency Contents Reply Command

'0'-'1' (30h, 32h): Display

ST: Status

00h: No Error

01h: Error

ETX (03h): End of Message

Check code

BCC: Block Check Code

Refer to the section 4.3 "Check code" for a BCC calculation.

Delimiter

CR (0Dh): End of packet

26.2 Emergency Contents Delete

This command is used in order to stop Emergency Contents.

- 1) The controller requests the monitor to set Security password.

Header	Message	Check code	Delimiter
SOH-'0'-Monitor ID-'0'-'A'-'0'-'8'	STX-'C'-'A'-'1'-'F'-'0'-'0'-ETX	BCC	CR

Header

SOH (01h): Start of Header
 '0' (30h): Reserved
 Monitor ID: Specify the Monitor ID of which you want to change a setting.
 Ex.) If Monitor ID is '1', specify 'A'.
 '0' (30h): Message sender is the controller.
 'A' (41h): Message type is "Command".
 '0'-'8'(30h,38h): Message length (8byte)

Message

STX (02h): Start of Message
 'C'-'A'-'1'-'F' (43h, 41h, 31h, 46h): Emergency Contents Command
 '0'-'0' (30h, 30h): Delete
 ETX (03h): End of Message

Check code

BCC: Block Check Code
 Refer to the section 4.3 "Check code" for a BCC calculation.

Delimiter

CR (0Dh): End of packet

- 2) The monitor replies a written in result.

Header	Message	Check code	Delimiter
SOH-'0'-'0'-Monitor ID-'B'-'0'-'A'	STX-'C'-'B'-'1'-'F'-'0'-'0'-ST-ETX	BCC	CR

Header

SOH (01h): Start of Header
 '0' (30h): Reserved
 '0' (30h): Message receiver is the controller.
 Monitor ID: Indicate a replying Monitor ID.
 Ex.) When this byte is set to 'A', replying monitor's ID is '1'.
 'B' (42h): Message type is "Command reply".
 '0'-'A'(30h,41h): Message length (10byte)

Message

STX (02h): Start of Message
 'C'-'B'-'1'-'F' (43h, 42h, 31h, 46h): Emergency Contents Reply Command
 '0'-'0' (30h, 31h): Delete
 ST: Error Status
 00h: No Error
 01h: Error
 ETX (03h): End of Message

Check code

BCC: Block Check Code
 Refer to the section 4.3 "Check code" for a BCC calculation.

Delimiter

CR (0Dh): End of packet

All data are subject to change without notice.

(November 16, 2016)

Copyright 2004-2016 NEC Display Solutions, Ltd. All Right Reserved

This document provides the technical information for users. NEC Display Solutions, Ltd. reserves the right to change or modify the information contained herein without notice. NEC Display Solutions, Ltd. makes no warranty for the use of its products and bears no responsibility for any errors or omissions which may appear in this document.